

**AD-4212D-33**

**AD-4212D-32**

**AD-4212D-302**

**AD-4212D-301**

**Production Weighing Unit**

**INSTRUCTION MANUAL**



**1WMPD4003129**

© 2016 A&D Company, Limited. All rights reserved.

No part of this publication may be reproduced, transmitted, transcribed, or translated into any language in any form by any means without the written permission of A&D Company, Limited.

The contents of this manual and the specifications of the instrument covered by this manual are subject to change for improvement without notice.

Windows and Excel are registered trademarks of Microsoft Corporation.

# CONTENTS

<b>1. INTRODUCTION</b> .....	<b>2</b>
1.1. Features .....	2
1.2. Compliance .....	5
<b>2. UNPACKING THE BALANCE</b> .....	<b>6</b>
2.1. Unpacking.....	6
2.2. Installing the Balance .....	8
<b>3. PRECAUTIONS</b> .....	<b>11</b>
3.1. Before Use .....	11
3.2. When Building Into a System .....	12
3.3. During Use .....	14
3.4. After Use.....	14
3.5. Power Supply .....	14
<b>4. BASIC OPERATON (WHEN USING THE AD-1691)</b> .....	<b>15</b>
4.1. Changing the Weighing Speed Using AD-1691 .....	16
4.2. Calibration .....	16
4.3. Calibration Using the Internal Weight.....	17
4.4. Calibration Using An External Weight .....	18
<b>5. SMART RANGE FUNCTION</b> .....	<b>19</b>
<b>6. UNDERHOOK</b> .....	<b>20</b>
<b>7. FUNCTION TABLE</b> .....	<b>21</b>
7.1. How to set (When using the AD-1691) .....	21
7.2. Details Of The Function Table .....	22
7.3. Description Of The Class "Environment, Display".....	24
7.4. Description Of The Item "Data Output Mode" .....	25
7.5. Description Of The Item "Data Format".....	26
7.6. Data Format Examples.....	29
<b>8. STANDARD INPUT AND OUTPUT INTERFACE</b> .....	<b>30</b>
8.1. RS-232C Interface.....	30
8.2. Commands .....	32
<b>9. MAINTENANCE</b> .....	<b>38</b>
9.1. Treatment Of The Balance .....	38
9.2. Error Codes .....	38
9.3. Checking The Balance Performance And Environment.....	40
9.4. Asking For Repair.....	40
<b>10. SPECIFICATIONS</b> .....	<b>41</b>
<b>11. EXTERNAL DIMENSIONS</b> .....	<b>42</b>
<b>12. OPTIONS</b> .....	<b>44</b>
<b>13. TERMS/INDEX</b> .....	<b>46</b>

# 1. INTRODUCTION

This manual describes how the AD-4212D series balance works and how to get the most out of it in terms of performance.

Read this manual thoroughly before using the balance and keep it at hand for future reference.

## 1.1. Features

- A compact Weighing Unit suitable for use in equipment for production line systems, draft chambers or glove boxes. The weighing unit is compact.
- The calibration using the internal calibration weight can easily be performed.
- A Super Hybrid Sensor is used to provide high resolution.

Model	Weighing capacity	Minimum weighing value	Stabilization time* <sup>1</sup>
AD-4212D-33	32g	0.001mg	7 seconds
AD-4212D-32	32g/5.1g* <sup>2</sup>	0.01mg/0.001mg* <sup>2</sup>	7 seconds
AD-4212D-302	320g	0.01mg	7 seconds
AD-4212D-301	320g	0.1mg	3 seconds

\*1 With **FAST** selected under good environment

\*2 Smart range (Refer to "5. SMART RANGE FUNCTION".)

- The AD-4212D series can output the weighing digital data directly. Therefore, the AD-4212D series (the weighing unit) can be connected to a personal computer or a PLC directly.
- The AD-4212D series has a patented shock absorber under the weighing pan and can cope with movement in all directions, protecting the weighing unit from an actuator malfunction.
- Connecting the provided AD-1691 balance environment analyzer to the AD-4212D allows the display of weighing values for the AD-4212D and manual operation of the re-zero and calibration functions.
- By using AD-1691, the environment of the AD-4212D (AND-MEET) can be evaluated. Results of AND-MEET can be saved in PDF format in USB memory.
- Installation of the options selected in the optional AD-8922A allows BCD, comparator and analog outputs.
- When connected to an optional remote controller, an AD-8923-BCD or AD-8923-CC, the remote controller can receive the weighing data and manually perform re-zero and calibration. The AD-8923-BCD outputs the data using BCD and the AD-8923-CC outputs the data using CC-Link.  
Note: CC-Link is a high-speed field network able to simultaneously handle both control and information data.
- When connected to an optional AD-8526 Ethernet converter, it can convert the AD-4212C RS-232C data, for output to a local area network (LAN).

**Example 1 (Connecting to a AD-1691, a personal computer or an AD-8922A)**

- When connecting to AD-1691 and PC  
 RS-232C cable for PC/PLC  
 (Sold separately: AX-KO4472-1000)

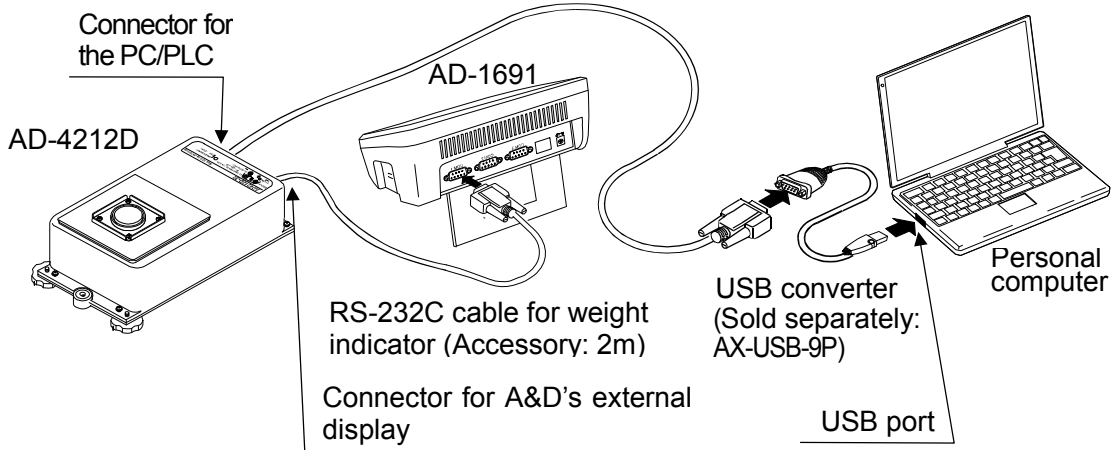

- When only connecting the AD-4212D to a PC

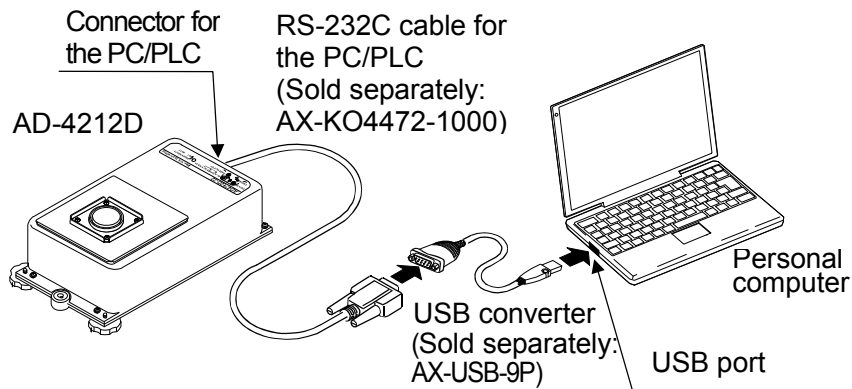

- When connecting the AD-4212D to the AD-8922A (External display) and PC

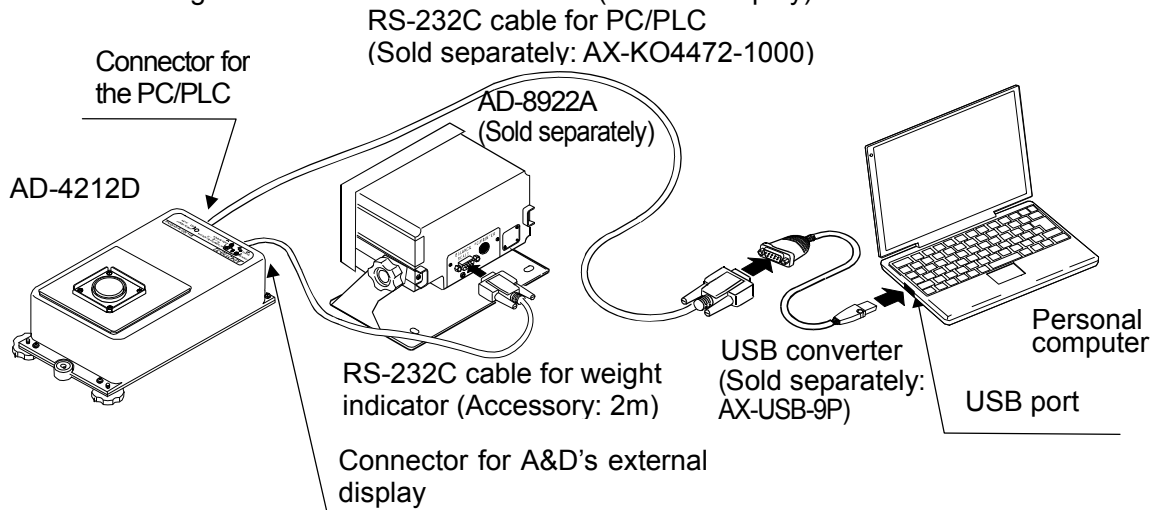

## Example 2 (Connecting to a PLC)

### ● When connecting using the RS-232C

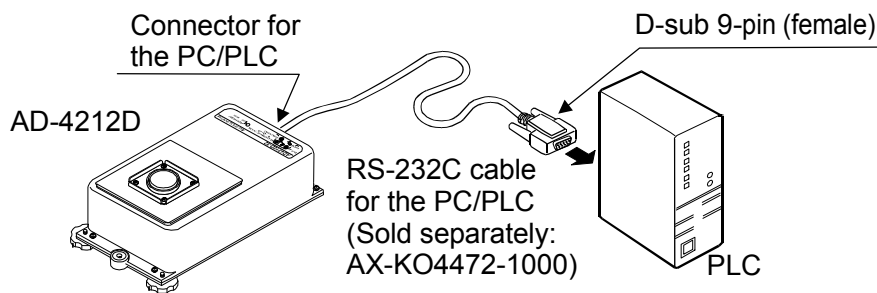

\* Depending on the PLC to be connected, a converter for the D-sub 9-pin plug may be required.

### ● When connecting using the BCD

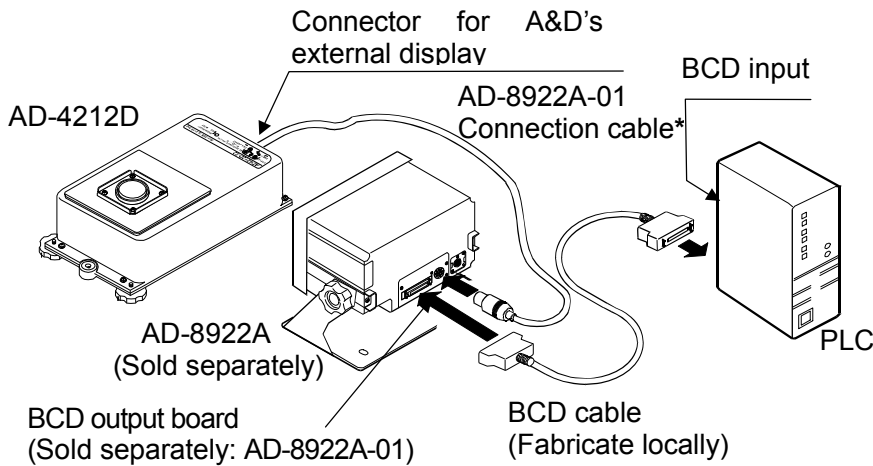

BCD output board  
(Sold separately: AD-8922A-01)

BCD cable  
(Fabricate locally)

\* Specify the AD-8922A-01 connection cable when ordering the AD-8922A-01.

AX-KO3705-200	2 m
AX-KO3705-500	5 m
AX-KO3705-1000	10 m

### ● When connecting using the CC-Link

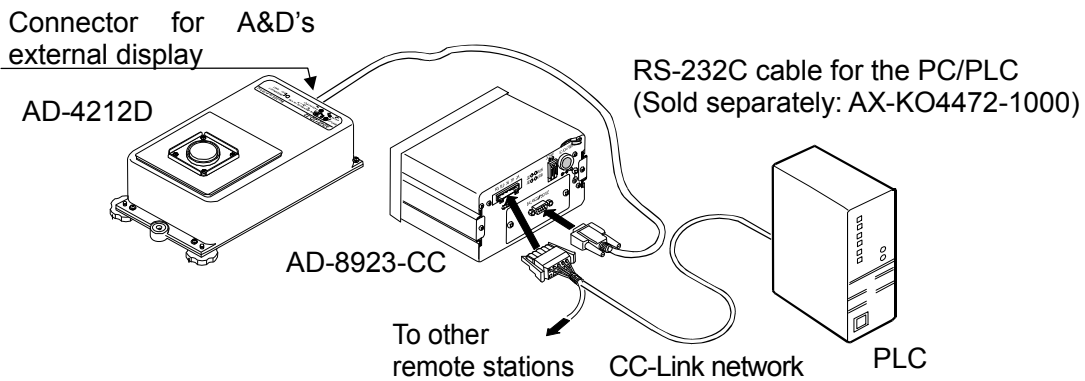

### ● When connecting to a LAN

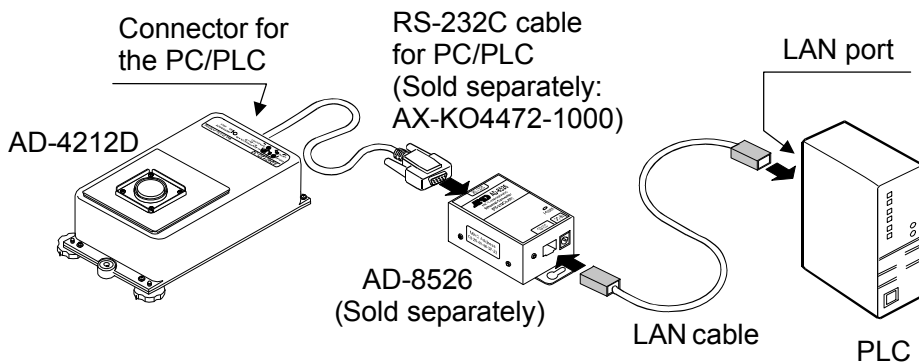

## 1.2. Compliance

---

### Compliance with FCC Rules

Please note that this equipment generates, uses and can radiate radio frequency energy. This equipment has been tested and has been found to comply with the limits of a Class A computing device pursuant to Subpart J of Part 15 of FCC rules. These rules are designed to provide reasonable protection against interference when the equipment is operated in a commercial environment. If this unit is operated in a residential area, it may cause some interference and under these circumstances the user would be required to take, at his own expense, whatever measures are necessary to eliminate the interference.

(FCC = Federal Communications Commission in the U.S.A.)

### Compliance With Directives of CE mark

**CE** This device features radio interference suppression, safety regulation and restriction of Hazardous Substances in compliance with the following Council Directives

Council directive 2004/108/EC EN61326 EMC directive

Council directive 2006/95/EC EN60950 Safety of Information Technology Equipment

Council directive 2011/65/EU EN50581 Restriction of the use of certain Hazardous Substances

- The CE mark is an official mandatory European marking.

Please note that any electronic product must comply with local laws and regulations when sold or used anywhere outside Europe..

## 2. UNPACKING THE BALANCE

### 2.1. Unpacking

- The balance is a precision instrument. Unpack the balance carefully. Keep the packing material to be used for transporting the balance in the future.
- When unpacking, see the illustration below to confirm that everything is contained.

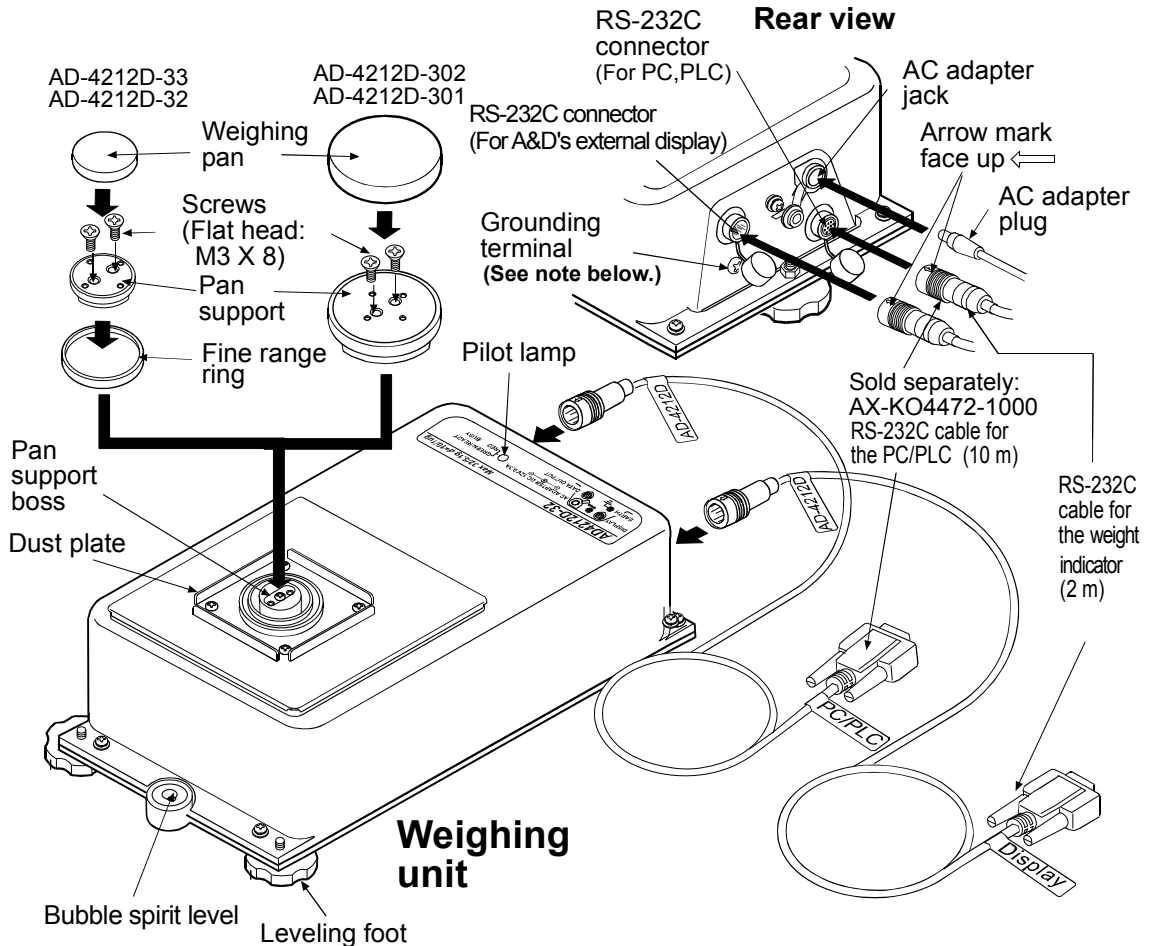

### Accessories

Waterproof cap for cleaning

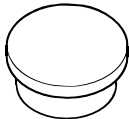

AC adapter \*

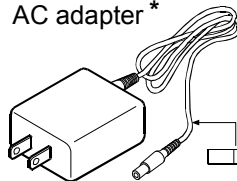

AC adapter ID label

Small breeze break

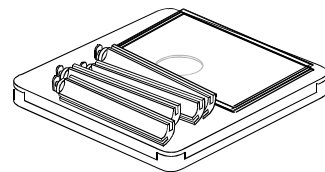

- RS-232C cable for the weight indicator (2 m) AX-KO3590-1000
- Weighing pan
- Pan support
- Screws (Flat head: M3 X 8)

Power plug stopper

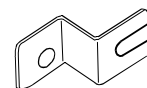

\* Please confirm that the AD adapter type is correct for your local voltage and receptacle type.

### Note

- When the AD-4212D series weighing unit is built into a system, be sure to earth ground the weighing unit using the grounding terminal.



## ATTACHING THE AD-4212D SERIES WEIGHING UNIT DIRECTLY ON THE MOUNTING BASE

When the AD-4212D series weighing unit is built into a system, remove the three leveling feet and use the screw holes to secure the weighing unit to the base.

### Attachment Procedure

1. Remove the three leveling feet.

#### Caution

**Do not remove any other screws from the bottom of the weighing unit. Doing so could damage the weighing sensor.**

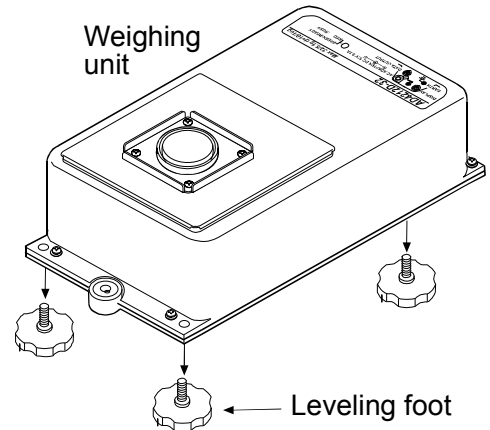

2. Secure the weighing unit from above.  
(Prepare appropriate screws with a size corresponding to an M5 screw. The screw hole diameter: 6 mm).

In case of securing the weighing unit from the under side, use M6 screws with 1-mm pitch.

#### Notes

- The screws to secure the weighing unit to the mounting base are not provided.
- For the position of the holes, refer to “11. EXTERNAL DIMENSIONS”.

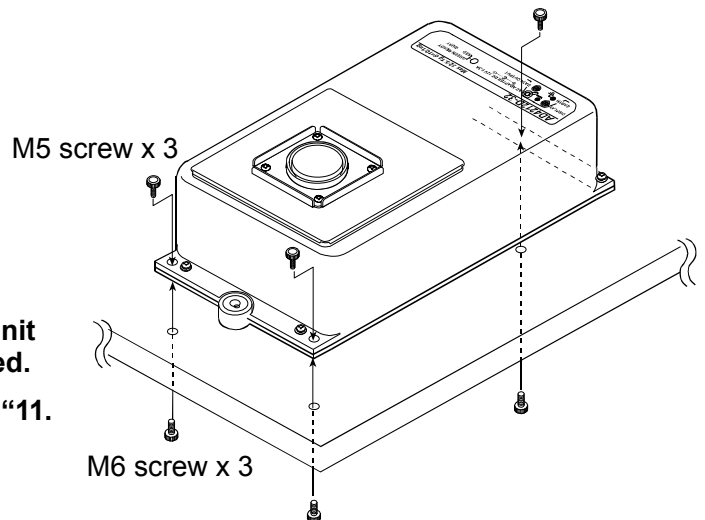

There are cases when an error in the leveling adjustment occurs due to the installation conditions. In this case, place a shim between the lower surface of the weighing unit and the securing surface, or use the double-nut method using M5 or M6 nuts to perform the height adjustment and secure it. If the adjustment is still difficult to perform, perform calibration before use. Then, the balance will function normally.

## 2.2. Installing the Balance

Install the balance as follows:

1. Refer to "3. PRECAUTIONS" for installing the balance.
2. Refer to "2. UNPACKING THE BALANCE" on page 6, to attach the pan support and the weighing pan on the weighing unit.
3. Insert the RS-232C cable into the jack located on the rear of the weighing unit.

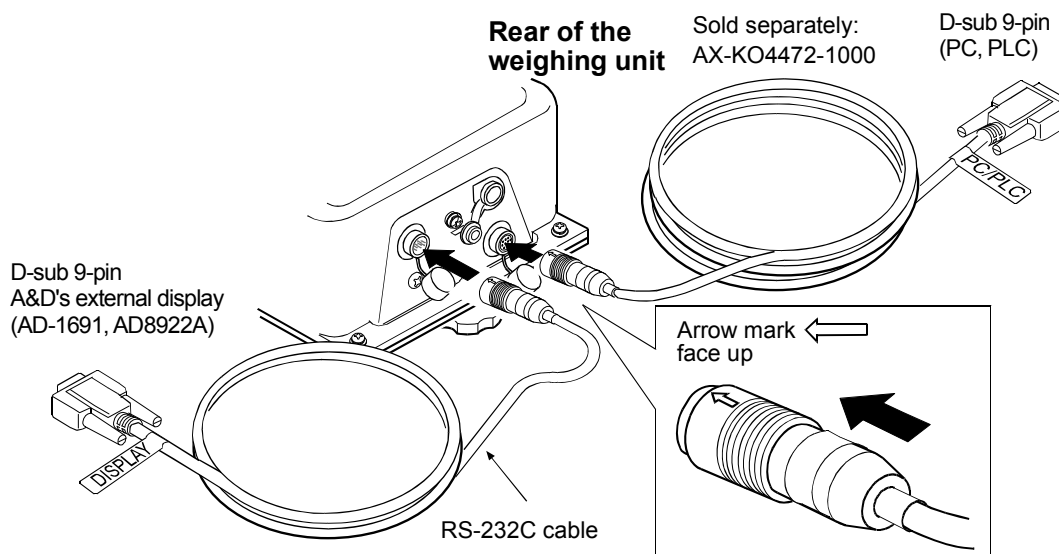

### How to disconnect the cable from the weighing unit

Slide the connector sleeve in the direction of the arrow to unlock and gently pull the connector out.

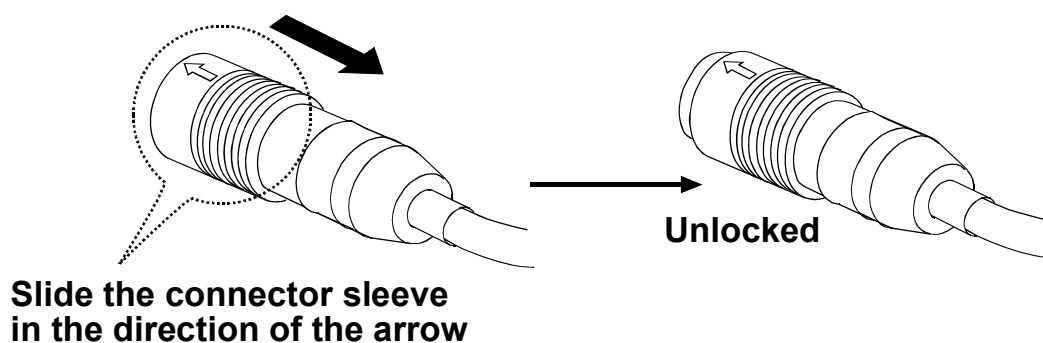

4. Follow the numerical sequence to assemble the small breeze break.

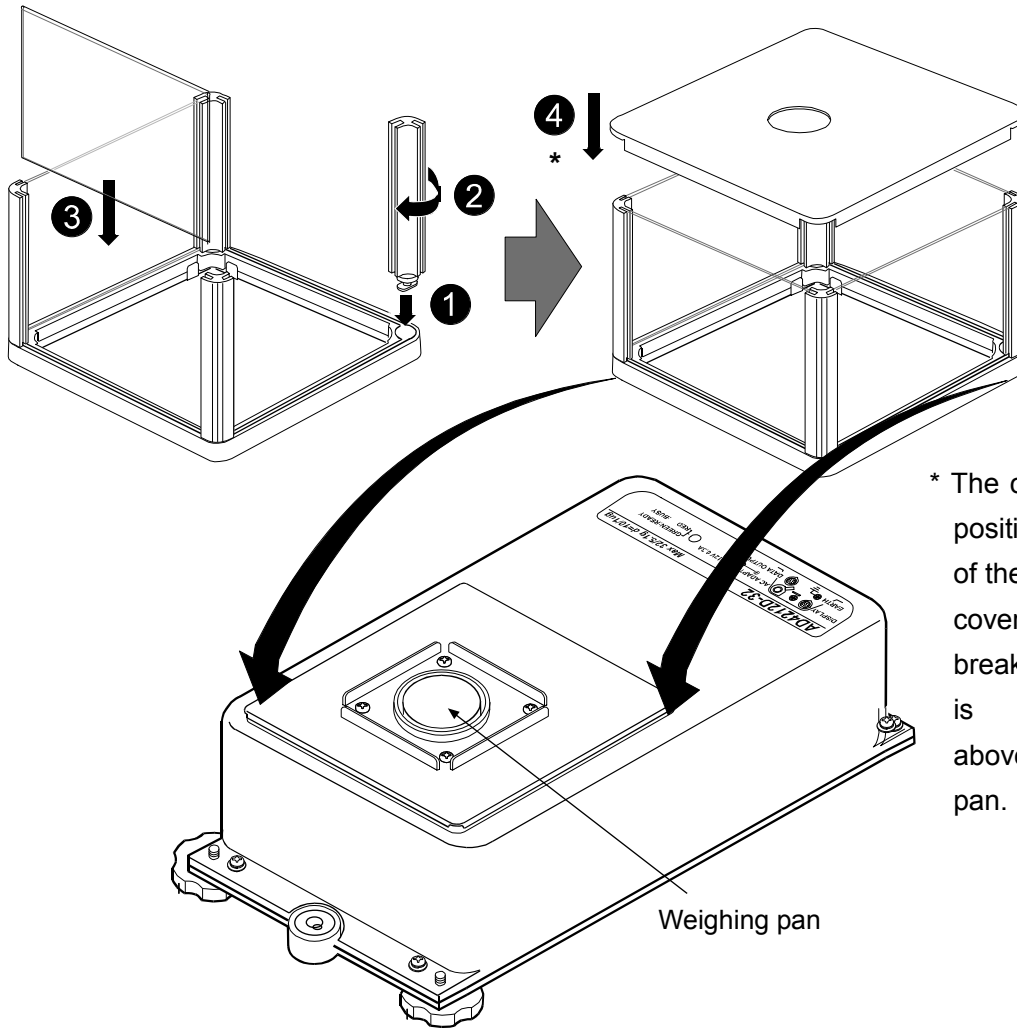

\* The cover's hole is not positioned in the center of the cover. Attach the cover on the breeze break so that the hole is positioned just above the weighing pan.

5. Confirm that the AC adapter type is correct for the local voltage and power receptacle type.

6. Plug the AC adapter plug into the AC adapter jack located on the rear of the weighing unit and plug the AC adapter into the electrical outlet. Warm up the balance for one hour or more with nothing on the weighing pan.

#### How to use the power plug stopper

- 1) Remove the screw attached on the main body.
- 2) Insert the power plug stopper to the slit at the thickest part of the AC adapter plug.
- 3) Insert the AC adapter plug into the AC adapter input jack and secure the power plug stopper to the main body with a screw.

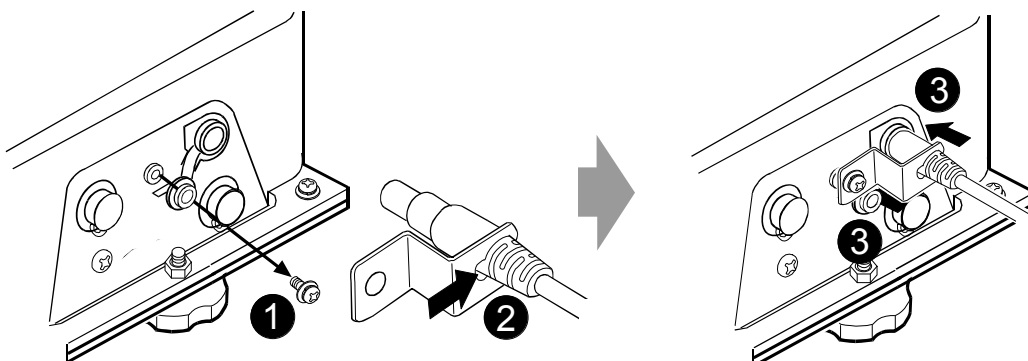

7. Set the pan unit and I/O unit to adapt to the peripheral system. Set the following for the I/O unit.
  - RS-232C (Refer to “8. STANDARD INPUT AND OUTPUT INTERFACE” )

Set the weighing speed to adapt to the ambient conditions.

**Note**

- **Make sure that the personal computer is in operation before connecting to the AD-4212D.**

8. After the balance has been installed, calibrate the balance using the internal weight or external calibration weight. For details, refer to “4.2. Calibration”.
9. By removing the provided weighing pan, a locally fabricated weighing pan can be attached to the AD-4212D series by using the four screw holes (M3 x 8) on the pan support.

**MASS OF THE LOCALLY FABRICATED WEIGHING PAN**

Design the weighing pan so that the mass falls within the ranges shown in the table below:

Model	Status	Mass of the weighing pan (g)
AD-4212D-33/32	Pan support is used (with weighing pan removed)	10 to 21
	Pan support boss is used (with the weighing pan and pan support removed)	35 to 46
AD-4212D-302/301	Pan support is used (with weighing pan removed)	20 to 230
	Pan support boss is used (with the weighing pan and pan support removed)	70 to 280

**AD-4212D-33/32**

**AD-4212D-302/301**

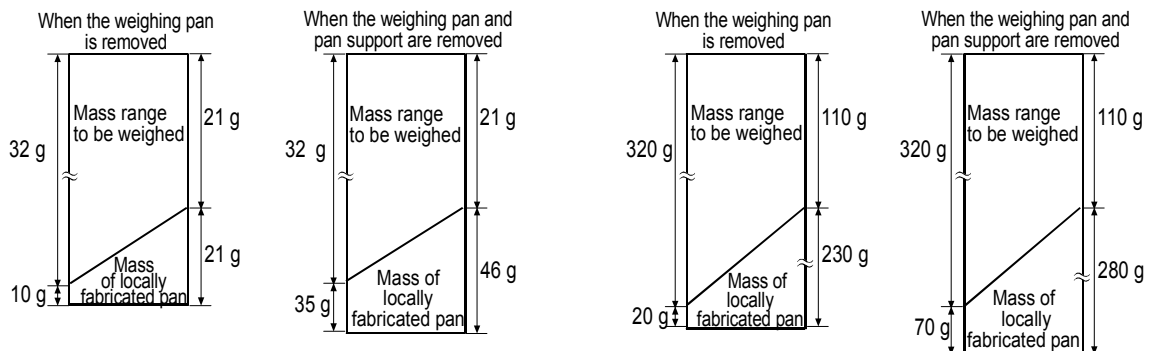

**Notes**

- **If the balance is to be used in a range other than shown above, contact the local A&D dealer.**
- **To avoid the effects of static electricity or magnetism, use materials other than resin or magnetic materials when designing a weighing pan.**
- **When a locally fabricated weighing pan is used, the zero point may be shifted greatly right after the AC adapter is plugged in. Perform re-zero before weighing to cancel the amount of zero drift as necessary.**

## 3. PRECAUTIONS

To get the optimum performance from the balance and acquire accurate weighing data, note the following:

### 3.1. Before Use

---

- Install the weighing unit in an environment where the temperature and humidity are not excessive. The best operating temperature is about 20°C / 68°F at about 50% relative humidity.
- Install the weighing unit where it is not exposed to direct sunlight and it is not affected by heaters or air conditioners.
- Install the weighing unit where it is free of dust.
- Install the weighing unit away from equipment which produces magnetic fields.
- Install the weighing unit in a stable place avoiding vibration and shock. Corners of rooms on the first floor are best, as they are less prone to vibration.
- Ensure a stable power source when using the AC adapter.
- Connect the power to the balance using the AC adapter at least one hour before use, but in the case of the AD-4212D-33/32, four hours are required. It is recommended to connecting the power to the balance.
- Calibrate the balance before use or after having moved it to another location.  
In addition, calibrate it periodically to maintain the accuracy.

#### **Caution**

**Do not install the balance where flammable or corrosive gas is present.**

## 3.2. When Building Into a System

### ● Errors due to a static charge and measures to take

When the ambient humidity is less than 45% RH, insulators such as plastic or glass are prone to static electricity. When charged material comes close to the balance, a pulling force is generated by static induction between the charged material and the weighing pan. This causes an unstable weight value.

To protect the balance against a discharge generated by charged material when it comes close to the balance, be sure to earth ground the weighing unit and the display unit.

Note that static electricity generated by static induction will not be canceled by earth-grounding. Use a humidifier or the AD-1683 DC static eliminator,

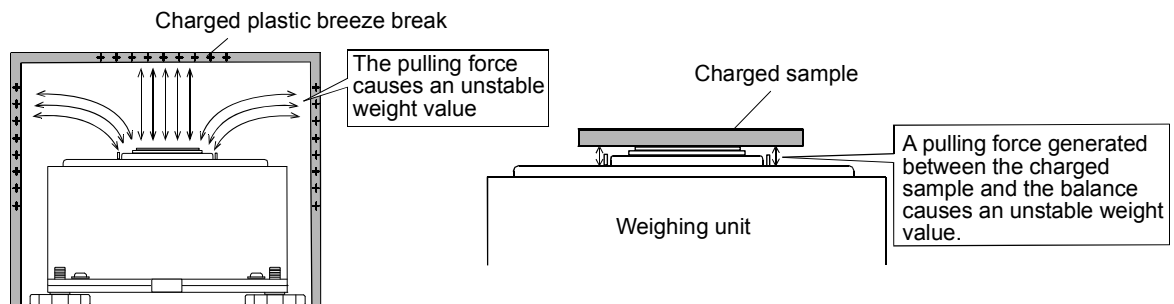

**Measures to take** (Plastic is used in the examples below. They can be applied to glass, too.)

- When the sample or devices are plastic
  - Use a static eliminator that generates no air blow such as the AD-1683, DC static eliminator, to remove static electricity.
  - Place the sample in a container that is made of a conductive material such as metal and that can be sealed, and then weigh it.
- When the sample is powdery
  - When the balance is used in combination with a feeder for batch weighing of powdery samples, samples may be charged by rubbing sample particles against each other. Use a static eliminator and perform weighing while removing static electricity.
- When the sample container is made of material that is prone to static electricity such as plastic
  - Cover the outside of the container with a metal such as aluminum foil.
  - Apply an anti-static agent onto the container.
- When making a breeze break using plastic
  - Apply an anti-static agent onto the breeze break.
  - Use a conductive acrylic fiber.
- When plastic exists in the balance installation site
  - Cover the plastic with a grounded conductive material.
  - Apply an anti-static agent onto the plastic.

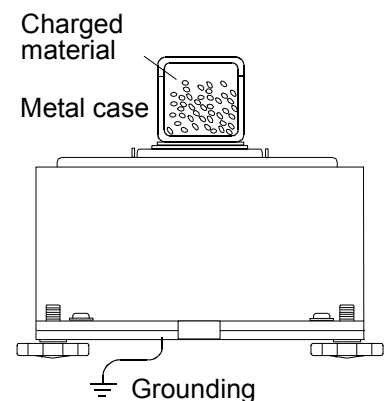

- When an operator is static charged

If an operator's clothes are static charged, especially in winter, it may be a cause for unstable weight values.

- Wear an anti-static wrist strap.

### ● Errors due to air flow and measures to take

- Where the influence of ambient air flow is great such as: close to an air conditioner or fan, door or passage way. Even very subtle air flow that is hard to be detected may influence the weighing operation.

- Avoid those areas as a weighing site.
- If weighing is to be performed in such an area, use a breeze break or take other appropriate measures.

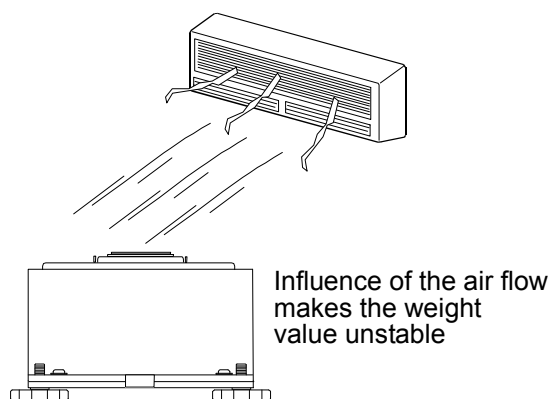

- Where the influence of heat or drafts is great
  - Eliminate temperature differences between a sample and the environment. When a sample is warmer (cooler) than the ambient temperature, the sample will be lighter (heavier) than the true weight. This error is due to a rising (falling) draft around the sample.

- Do not touch the sample directly with your hand. Use tweezers or other tools. If you touch the sample, the same type error described above will occur.

- Do not perform weighing where it is exposed to direct sunlight. Weighing errors may occur due to sudden temperature change or drafts.

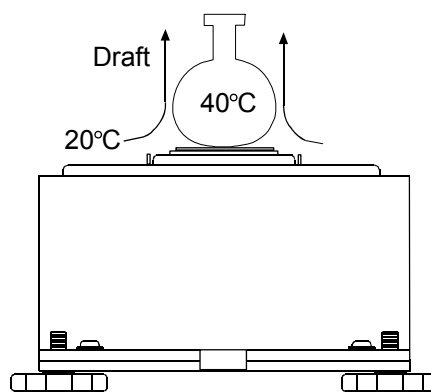

### ● Errors due to vibration and measures to take

- Where the influence of vibration is great, such as:

(1) Soft ground (2) Second or higher floor (3) Near center of a floor far from pillars (4) Seismic isolated structures (5) Near tall buildings.

In the areas listed above, the scale may yield unstable weight values on windy days or after an earthquake. Especially in case of (4) and (5), weight values may be unstable for a long period of time because of long lasting low-frequency vibration after strong winds or an earthquake.

### ● Errors due to other causes and measures to take

- Change in temperature or humidity

A sudden change in temperature or humidity can generate a draft and cause the balance to absorb or exude moisture, which leads to unstable displays.

- Avoid sudden change in temperature or humidity.
- Use an air conditioner or humidifier to control the temperature or humidity.

- Magnetic material

The balance uses a strong magnet as part of the balance assembly, so use much care when weighing magnetic materials.

- Place a non-magnetic object such as aluminum or brass between the sample and the balance to keep an appropriate distance between them while weighing.

### 3.3. During Use

---

- To minimize the affect by electrical noises, earth ground the weighing unit and the display unit (option).
- Do not drop things upon the weighing pan, or place a sample on the pan that is beyond the balance weighing capacity. Place a sample in the center of the weighing pan to minimize corner-load errors.
- To prevent possible errors, before each weighing, perform re-zero using the RS-232C command, or calculate the difference between the weight value before and after weighing.
- Take into consideration the affect of air buoyancy on a sample when measuring the absolute value with the minimum weighing value of 0.1 mg.
- While cleaning, attaching the waterproof cap to the unit instead of the weighing pan results in the AD-4212D becoming dust-proof and drip-proof and conforming to IP65. Be sure to clean the weighing pan and keep the conditions around the pan clean after weighing powdery, fluid samples or metallic strips.
- Balance status is indicated by the pilot lamp.

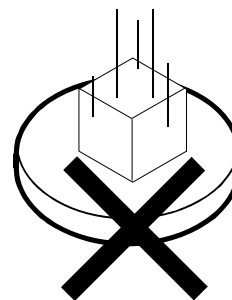

Lamp status	Balance status
Turned off	The power with the balance is not turned on.
Green	Weighing mode
Red	When turning on the power, when an error has occurred, or during a re-zero or calibration

### 3.4. After Use

---

- Avoid mechanical shock to the weighing unit.
- Periodically calibrate the balance using the internal weight or a calibration weight.
- Do not disassemble the weighing unit. Contact the local A&D dealer if the balance needs service or repair.
- Do not use organic solvents to clean the weighing unit. Clean the weighing unit with a lint free cloth that is moistened with warm water and a mild detergent.
- Avoid dust and water so that the weighing unit weighs correctly. Protect the internal parts from liquid spills and excessive dust.

### 3.5. Power Supply

---

- When the AC adapter is connected, the balance is in the standby mode if the standby indicator is on (refer to “4. BASIC OPERATON (WHEN USING THE AD-1691)”). This is a normal state and does not harm the balance. For accurate weighing, plug in the AC adapter and warm up the balance for the appropriate duration before use.



## 4. BASIC OPERATON (WHEN USING THE AD-1691)

Using the provided AD-1691 weighing environment analyzer as a remote controller enables performing the following functions.

- Weighing value display
- Calibration
- Changing of the minimum display digit
- Changing of the weighing speed (Response)
- Re-zero

### Preparations before use

1. Connect the RS-232C connector for the A & D's external display to the AD1691's arbitrary RS-232C connector using the cable.  
\* Factory setting of the AD1691 is set to COM1.
2. Connect the AD-4212D to the power using the AC adapter to turn the power on and put the AD-4212D to weighing mode.
3. Connect the AD-1691 to the power using the AC adapter and turn the power on.
4. Perform functions as the balance weighing display from the home screen.
5. Touch the **Start** button to display the weighing value.  
\* AD-4212D weighing indicator RS-232C has a fixed 2400bps baud rate with parity-even and data bits-7 bits.

### Descriptions for the display and buttons

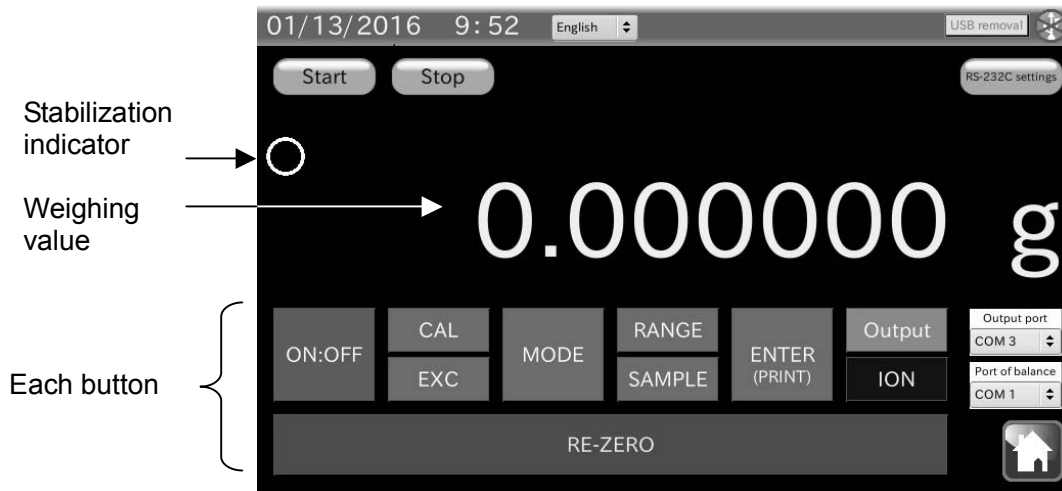

Button	Function
<b>ON:OFF</b>	Toggles between the weighing mode and standby mode.
<b>CAL</b>	Performs the calibration using the internal weight.
<b>EXC</b>	Performs the calibration using the calibration weight.
<b>MODE</b>	Changes the weighing speed (Response speed).
<b>RANGE / SAMPLE</b>	Changes the minimum display digit.
<b>ENTRE(PRINT)</b>	Outputs the weighing value. (COM port that is set at the external output port)
<b>RE-ZERO</b>	Sets the display value to zero.
<b>Output</b>	Outputs the current weighing value.
<b>ION</b>	Has no function.

## 4.1. Changing the Weighing Speed Using AD-1691

The weighing speed can be selected from the following three rates to minimize the influence on weighing that is caused by drafts and/or vibration at the place where the balance is installed.

Indicator	Speed	Stability
FAST	Fast	Sensitive value
MID.	↑	↓
SLOW	Slow	Stable value

Weighing speed setting

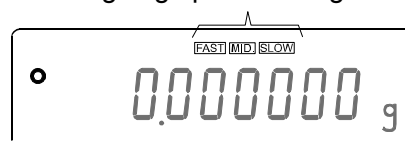

### Operation

1. Touch the **MODE** button to select a weighing speed.  
Either **FAST**, **MID.** or **SLOW** can be selected.

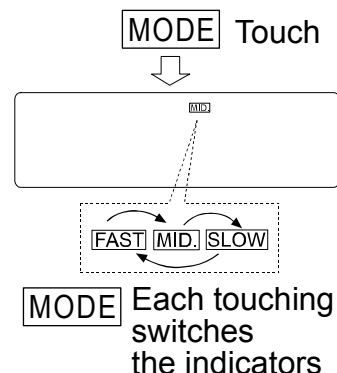

## 4.2. Calibration

### Calibration

Calibration using the calibration weight.

### Caution

- Do not allow vibration or drafts to affect the balance during calibration.

### Caution on using an external calibration weight

- The accuracy of the weight can influence the accuracy of weighing. Select an appropriate weight as listed below.

Model	Usable calibration weight
AD-4212D-30/32	1g, 2g, 5g, 10g, <b>20g</b> , 30g
AD-4212D-302/301	10g, 20g, 50g, 100g, <b>200g</b> , 300g

The calibration weight in bold type: factory setting

### Display



- This indicator means “the balance is measuring calibration data”. Do not allow vibration or drafts to affect the balance while this indicator is displayed.

### 4.3. Calibration Using the Internal Weight

---

This function calibrates the balance using the internal weight.

- 1 Connect the AC adapter and warm up the balance for at least one hour with nothing on the weighing pan.
- 2 Touch the **CAL** key to display **CAL in** .
- 3 The balance performs calibration using the internal weight. Do not allow vibration or drafts to affect the balance.
- 4 The balance will automatically return to the weighing mode after calibration.

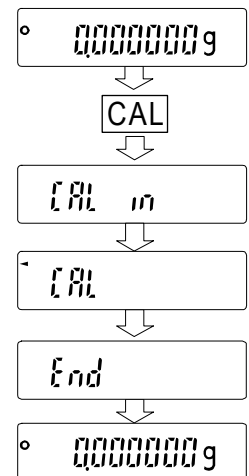

## 4.4. Calibration Using An External Weight

### Calibration procedure

This function calibrates the balance using the calibration weight. (Display example: AD-4212D-301)

#### Operation

1. Plug in the AC adapter and warm up the balance for 30 minutes or more with nothing on the pan.
2. Touch the **EXC** button. **CAL 0** is displayed.
  - If you want to cancel calibration, touch the **CAL** button. The balance will return to the weighing mode.
  - If you want to change the calibration weight value, press the **SAMPLE** button. Touch the **RE-ZERO** button to select the weight value, and touch the **ENTER** button to store it. **CAL 0** is displayed.
3. Confirm that there is nothing on the pan and touch the **ENTER** button. The balance measures the zero point. Do not allow vibration or drafts to affect the balance. The balance displays the calibration weight value.
4. Place a calibration weight, of the weight value displayed, on the pan and touch the **ENTER** button. The balance measures the calibration weight. Do not allow vibration or drafts to affect the balance.
5. The balance displays **End**. Remove the weight from the pan.
6. The balance will automatically return to the weighing mode.
7. Place the calibration weight on the pan and confirm that calibration was performed correctly. If not, check the ambient conditions such as drafts or vibration, and repeat steps 2 through 7.



## 5. SMART RANGE FUNCTION

The AD-4212D-32 is equipped with two ranges. The precision range has a higher resolution. The standard range has a normal resolution.

The range switches automatically depending on the value displayed. Touching the **RE-ZERO** button or sending the R command allows weighing in the precision range regardless of the tare value. The range can be fixed to the standard range by changing the minimum weighing value using the **RE-ZERO** button or R command.

- 1 Touch the **RE-ZERO** button or send the R command.  
The balance will start weighing, using the precision range.
- 2 Place a container on the weighing pan.  
The weight value exceeds the precision range value and the balance will switch to the standard range.
- 3 Touch the **RE-ZERO** button or send the R command.  
The balance will switch to the precision range.
- 4 Place a sample in the container.  
The weight value is within the precision range value and the balance will perform a weighing, using the precision range.

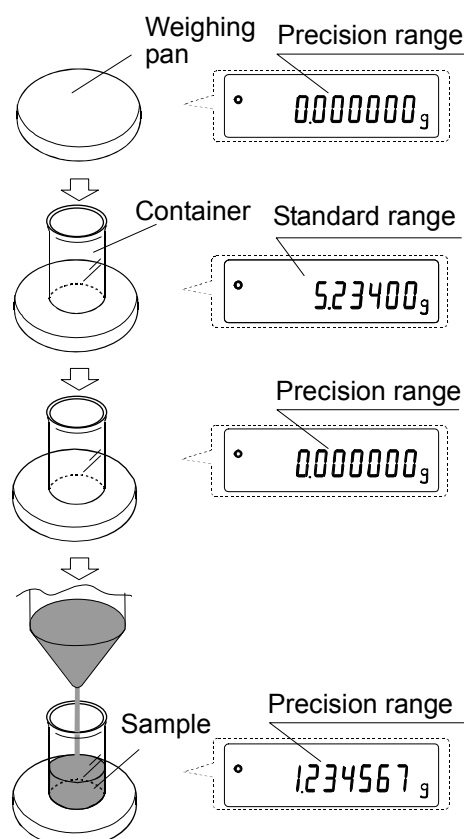

### Precision range/standard range

Model	Range used	Weighing range	Available minimum weighing value
<b>AD-4212D-32</b>	Precision range*	0 g to 5.1 g	0.000001g (0.001mg)
	Standard range	5.1 g to 32 g	0.00001g (0.01mg)

- The factory setting is the precision range.

\* When the weight value exceeds 5.1 g while the minimum weighing value of 0.000001 g (precision range) is used, the balance will switch to the minimum weighing value of 0.00001 g (standard range). By touching the **RE-ZERO** button or sending the R command, the balance can weigh from that point up to 5.1 g, using the minimum weighing value of 0.000001 g (precision range).

## 6. UNDERHOOK

The underhook can be used for magnetic materials or density measurement. The built-in underhook is revealed by removing the cap on the bottom of the balance. Use the underhook as shown below.

### Caution

- Do not apply excessive force to the underhook.
- When not in use, attach the cap to prevent dust from getting into the balance.
- Do not push the underhook upward
- When turning the balance over, parts and weighing matter in the weighing chamber will fall off. (Parts: the weighing pan and fine range ring) Remove them first.
- When the cap is removed, a weighing error may occur, because of drafts entering into the internal portion of the balance. Arrange the room condition.

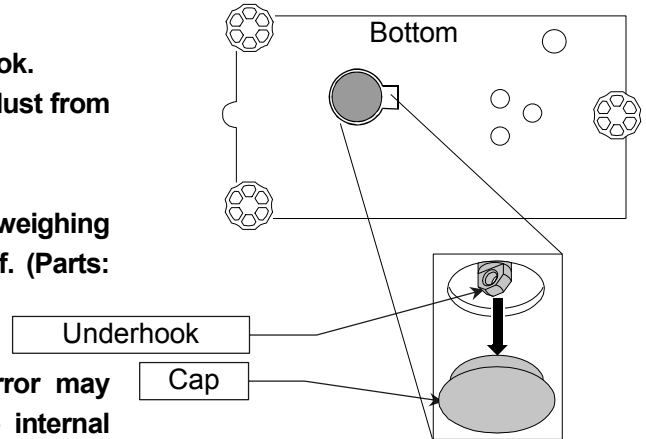

### How to use

- 1 Remove the cap on the bottom of the balance.
- 2 Hang your weighing pan on the underhook.  
Place the balance on the solid table.

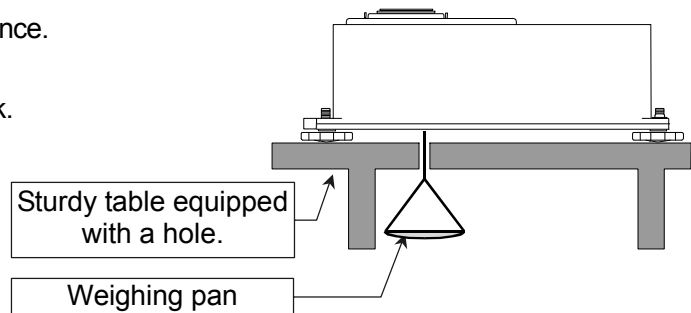

# 7. FUNCTION TABLE

The function table reads or rewrites the parameters that are stored in the balance.

These parameters are maintained in non-volatile memory, even if the AC adapter is removed.

The function table menu consists of two layers. The first layer is the "Class" and the second layer is the "Item".

## 7.1. How to set (When using the AD-1691)

Using the provided AD-1691 weighing environment analyzer as a remote controller enables changes or confirmation of function settings.

1. Connect the RS-232C connector for the A&D's external display to the AD-1691's arbitrary RS-232C connector using the cable.
2. Connect the AD-4212D to the power using the AC adapter to turn on the power and have the AD-4212D enter the weighing mode.
3. Connect the AD-1691 to the power using the AC adapter and turn the power on.
4. Perform the balance function settings at the AD-1691.

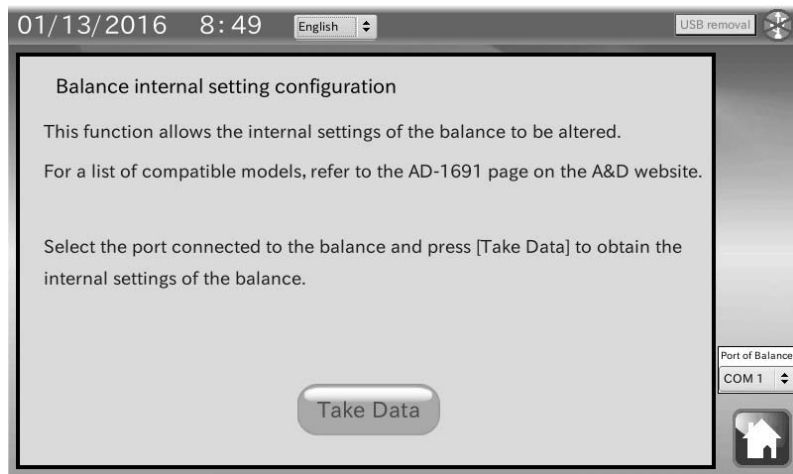

5. Touch the **Take Data** button to start communication between the AD-1691 and AD-4212D.
6. The screen shows the function settings list.

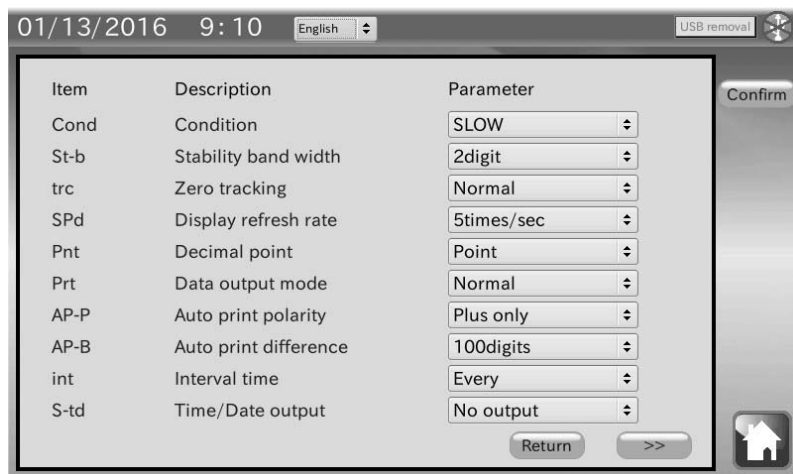

7. Click the arrow mark to change the setting values.

\* The changed contents have yet to be confirmed at this step.

8. Touch the **Confirm** button to start the communication and change the balance function settings.  
The device will be restarted when the setting changes were ended.

## 7.2. Details Of The Function Table

Class	Item and Parameter	Description		
bRSFnc Environment Display	Cond Condition	0	Fast response, sensitive value	<div style="display: flex; align-items: center;"> <div style="border: 1px solid black; padding: 2px; margin-right: 5px;">FAST</div> <div style="border: 1px solid black; padding: 2px; margin-right: 5px;">MID.</div> <div style="border: 1px solid black; padding: 2px; margin-right: 5px;">SLOW</div> <div style="margin-left: 10px;">Can be changed by response adjustment.</div> </div>
		1		
		2	Slow response, stable value	
	St-b Stability band width	0	Stable range is ±1 digit	The stabilization indicator illuminates when the display fluctuation is within the range.
		1	±2 digit #1	
		2	Stable range is ±3 digits	
	PLoc Display lock function	OFF	OFF	Display hold function to measure the volume dispensed from the pipette.
ON		ON		
Trc Zero tracking	0	OFF	Keeps zero display by tracking zero drift.	
	1	Normal		
	2	Strong		
SPd Display refresh rate	0	5 times/second #3	Period to refresh the display	
	1	10 times/second #3		
Pnt Decimal point	0	Point (.)	Decimal point format	
	1	Comma (,)		
dout Data output #4	Prt Data output mode	0	Normal mode	Outputs data by commands.
		1	Auto print mode A Reference = zero	Outputs data when the display is stable and conditions of RP-P, RP-b and the reference value are met.
		2	Auto print mode B Reference = last stable value	
	RP-P Auto print polarity	0	Plus only	Displayed value > Reference
		1	Minus only	Displayed value < Reference
		2	Both	Regardless of displayed value
	RP-b Auto print difference	0	10 digits	Difference between reference value and displayed value #2
1		100 digits		
2		1000 digits		

▪ : Factory settings.

#1 The unit of minimum display is digit.

Example: If 1 mg display is selected touching the RANGE button for the AD4212D-301, 1 mg is one digit.

#2 Usable minimum display of the balance is one digit.

Example: In gram display, one digit is 0.00001 mg for the AD4212D-302 and 0.0001 mg for the AD4212D-301.

#3 Factory settings of the AD4212D-33 and AD4212D-32 is set to 5 times per second.

Factory settings of the AD4212D-302 and AD4212D-301 is set to 10 times per second.

#4 These items apply only for RS-232C output for the PC or PLC.



Class	Item and Parameter	Description				
<i>dout</i> Data output #4	<i>int</i> Interval time	▪ 0	Every measurement	Interval time in the interval memory mode when using <i>Pr t 3</i>		
		1	2 seconds			
		2	5 seconds			
		3	10 seconds			
		4	30 seconds			
		5	1 minutes			
		6	2 minutes			
<i>dout</i> Data output #4	<i>S-t d</i> Time/Date output	▪ 0	No output	Selects whether or not the time or date is added to the weighting data.		
		1	Time only			
		2	Date only			
		3	Time and date			
		<i>S- id</i> ID number output	▪ <i>oFF</i>		No output	Selects whether or not the ID number is output.
			<i>oN</i>		Output	
		<i>PUSE</i> Data output pause	▪ <i>oFF</i>		No pause	Selects the data output interval.
<i>oN</i>	Pause (1.6 seconds)					
<i>Rt-F</i> Auto feed	▪ <i>oFF</i>	Not used	Selects whether or not automatic feed is performed.			
	<i>oN</i>	Used				
<i>Rr-d</i> Zero after output	▪ <i>oFF</i>	Not used	Adjusts zero automatically after data is output			
	<i>oN</i>	Used				
<i>S-tP</i> Temperature output	▪ <i>oFF</i>	Not output	Adds temperature to data output			
	<i>oN</i>	Output				
<i>S iF</i> Serial interface #4	<i>bPS</i> Baud rate	0	600 bps			
		1	1200 bps			
		▪ 2	2400 bps			
		3	4800 bps			
		4	9600 bps			
	<i>btPr</i> Data bit, parity bit	▪ 0	7 bits, even			
		1	7 bits, odd			
		2	8 bits, none			
	<i>Cr-LF</i> Terminator	▪ 0	CR LF	CR: ASCII code 0Dh		
		1	CR	LF: ASCII code 0Ah		
<i>tYPE</i> Data format	▪ 0	A&D standard format	Refer to "7.5. Description Of The Item "Data Format" ".			
	1	DP format				
	2	KF format				
	3	MT format				
	4	NU format				
<i>S iF</i> Serial interface #4	<i>t-UP</i> Timeout	▪ <i>oFF</i>	No limit	Selects the wait time to receive a command.		
		▪ <i>oN</i>	1 second			
<i>S iF</i> Serial interface #4	<i>ErCd</i> AK, Error code	▪ <i>oFF</i>	No output	AK: ASCII code 06h		
		▪ <i>oN</i>	Output			

▪ : Factory settings.

Caution The balance may not transmit the data completely at the specified refresh rate, depending on the baud rate or data added to the weighing data such as time, date and ID number.

#4 These items apply only for RS-232C output for the PC or PLC.

## 7.3. Description Of The Class "Environment, Display"

---

### Condition ( $Cond$ )

$Cond \ 0$  This parameter is for sensitive response to the fluctuation of a mass value. Used for powder target mass, weighing a very light sample or when quick response weighing is required.



$Cond \ 2$  This parameter is for stable weighing with slow response. Used to prevent a mass value from drifting due to vibration or drafts.

**Notes** In automatic response adjustment, this parameter is selected automatically.

### Stability band width ( $St-b$ )

This item controls the width to regard a mass value as a stable value. When the fluctuation per second is less than the parameter, the balance displays the stabilization indicator and outputs. The parameter influences the "Auto print mode". Currently displayed minimum display means 1 digit.

Example) If the RANGE button was touched to select the 1 mg display at the AD4212D-301, 1 mg means 1 digit.

$St-b \ 0$  This parameter is used for sensitive response of the stabilization indicator. Used for exact weighing.



$St-b \ 2$  This parameter ignores slight fluctuations of a mass value. Used to prevent a mass value from drifting due to vibration or drafts.

### Zero tracking ( $trc$ )

This function tracks zero point drift caused by changes in the environment and stabilizes the zero point. When the weighing data is only a few digits, turn the function off for accurate weighing.

$trc \ 0$  The tracking function is not used. Used for weighing a very light sample.

$trc \ 1$  The normal tracking function is used.

$trc \ 2$  The strong tracking function is used.

$trc \ 3$  The very strong tracking function is used. Used for stable zero display.

### Display refresh rate ( $SPd$ )

The periodic time to refresh the display. This parameter influences "Baud rate", "Data output pause" and the data output rate of "Stream mode".

### Decimal point ( $Pnt$ )

The decimal point format can be selected.

## 7.4. Description Of The Item "Data Output Mode"

The parameter setting of "Data output mode (*Prt*)" applies to the performance when the data is transmitted using the RS-232C interface.

### Normal mode

The output is performed only when receiving a command such as a Q command.

Required setting    *dout Prt 0*    Normal mode

### Auto print modes A and B

When the displayed value is stable and the conditions of "Auto print polarity", "Auto print difference" and reference value are met, the balance outputs the weighing data once.

#### Auto print mode A

Example                      For weighing each time a sample is placed and removed, with "*Rr-d*" set to "*!*" (to adjust zero after the data is output).

Required setting    *dout Prt 1*    Auto print mode A (reference = zero)  
*dout RP-P*    Auto print polarity  
*dout RP-b*    Auto print difference  
*dout Rr-d on*    Zero after output

#### Auto print mode B

Example                      For weighing while a sample is added.

Required setting    *dout Prt 2*    Auto print mode B (reference = last stable value)  
*dout RP-P*    Auto print polarity  
*dout RP-b*    Auto print difference

### Stream mode

The balance outputs the weighing data continuously regardless of the display condition. When the display refresh rate is set to 5 times / second (*SPd 0*), the data output rate is also set to the same 5 times / second. The display does not blink in this mode.

Example                      For monitoring data on a computer.

Required setting    *dout Prt 3*    Stream mode  
*bRSFnc SPd*    Display refresh rate  
*S iF bPS*    Baud rate

**Caution**    The balance may not transmit the data completely at the specified refresh rate, depending on the baud rate or time, date and ID number appended to the weighing data.

### Interval mode

The weighing data is periodically output.

Example                      In case of monitoring the weighing value periodically, the time and date can be added to the weighing data depending on settings of *S-t d*.

Required setting    *dout Prt 3*    Interval mode  
*dout int*    Interval time

## 7.5. Description Of The Item "Data Format"

\* The output data format applies only to RS-232C output for the PC or PLC.

### A&D standard format

SIF TYPE 0

This format is used when the peripheral equipment can receive the A&D format.

- This format consists of fifteen or sixteen characters excluding the terminator.
- When numerical characters without decimal point are eight characters for the AD-4212D-30, AD-4212D-32 and AD-4212D-302, the format becomes sixteen characters.
- A header of two characters indicates the balance condition.
- The polarity sign is placed before the data with the leading zeros. If the data is zero, the plus sign is applied.
- The unit, consisting of three characters, follows the data.

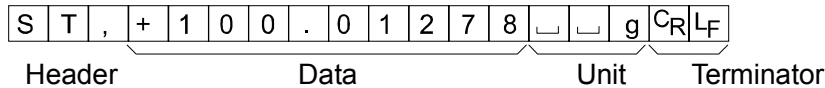
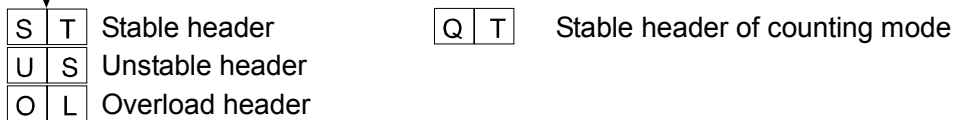
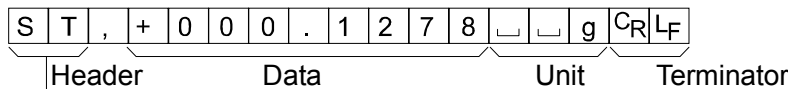

### DP (Dump print) format

SIF TYPE 1

- This format consists of sixteen characters excluding the terminator.
- A header of two characters indicates the balance condition. No overload header is used.
  - The polarity sign is placed before the data, with spaces in place of leading zeros, if the data is not zero or overloaded.
- The unit, consisting of three characters, follows the data.

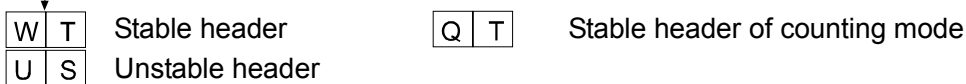
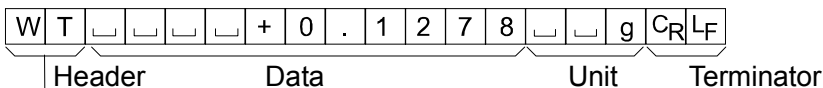

### KF format

SIF TYPE 2

This is the Karl-Fischer moisture meter format and is used when the peripheral equipment can only communicate using this format.

- This format consists of fourteen characters excluding the terminator.
- This format has no header characters.
- The polarity sign is placed before the data, with spaces in place of leading zeros, if the data is not zero or overloaded.
- This format outputs the unit only for a stable value.

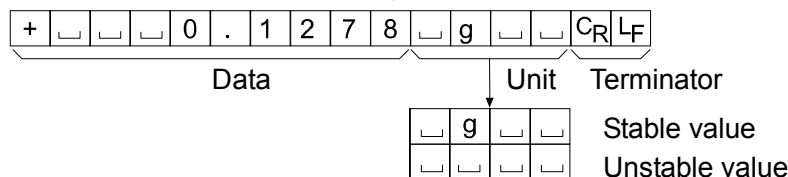

## MT format

S, F TYPE 3

This format is used when the peripheral equipment of other manufacturer is connected. Please note that the connection is not guaranteed.

- A header of two characters indicates the balance condition.
- The polarity sign is used only for negative data.
- The weighing data uses spaces in place of the leading zeros.
- The character length of this format changes dependent upon the unit

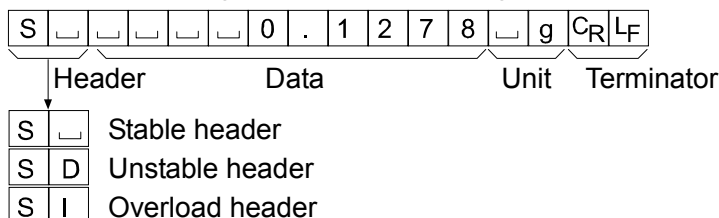

## NU (numerical) format

S, F TYPE 4

This format outputs only numerical data.

- This format consists of ten characters excluding the terminator.
- The polarity sign is placed before the data with the leading zeros. If the data is zero, the plus sign is used.

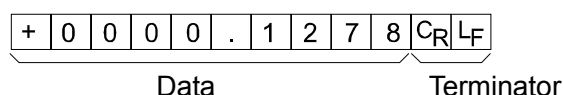

## CSV format

S, F TYPE 5

- This format separates the data of A&D standard format and the unit by a comma ( , ).
- This format outputs the unit even when the data is overloaded.
- When a comma ( , ) is selected for the decimal point, the separators are set to semicolon ( ; ).
- When the ID number, time and date are added at "Data output (*dout*)" of the function table, outputs ID number, date, time and weighing data in this order and separates each item by a comma and treats all the items as one group of data.

LAB-0123, 
 2004/07/01, 
 12:34:56, 
 ST,+0000.1278, 
   g
 <CR><LF>

LAB-0123   
 2004/07/01   
 12:34:56   
 ST,+0000.1278   
   g

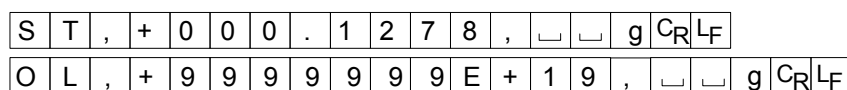

## ID number

*dout* S- id on

The number to identify a specific balance.

- This format consists of eight characters excluding the terminator.

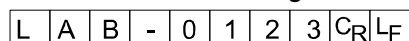

## Date

*dout* S-td 2 or 3

- The date output order can be changed in " Time/Date output (*S-td*)" .  
The year is output in a four-digit format.

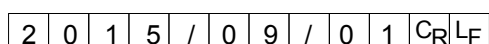

## Time

*dout 5-td 1 or 3*

- This format outputs time in 24-hour format.

1	2	:	3	4	:	5	6	C <sub>R</sub>	L <sub>F</sub>
---	---	---	---	---	---	---	---	----------------	----------------

## Temperature

*dout 5-tP on*

- This format outputs temperature. The unit is "C".

**Caution** Humidity and air pressure are not output.

+	0	2	3	.	4	_	_	C	C <sub>R</sub>	L <sub>F</sub>
---	---	---	---	---	---	---	---	---	----------------	----------------

## 7.6. Data Format Examples

### Stable

° 0.1278 g

° 1000.1278 g

A&D	S	T	,	+	0	0	0	.	1	2	7	8	␣	␣	g	C <sub>R</sub>	L <sub>F</sub>	
	S	T	,	+	1	0	0	.	0	1	2	7	8	␣	␣	g	C <sub>R</sub>	L <sub>F</sub>
DP	W	T	␣	␣	␣	␣	+	0	.	1	2	7	8	␣	␣	g	C <sub>R</sub>	L <sub>F</sub>
KF	+	␣	␣	␣	0	.	1	2	7	8	␣	g	␣	␣	C <sub>R</sub>	L <sub>F</sub>		
MT	S	␣	␣	␣	␣	␣	0	.	1	2	7	8	␣	g	C <sub>R</sub>	L <sub>F</sub>		
NU	+	0	0	0	0	.	1	2	7	8	C <sub>R</sub>	L <sub>F</sub>						

### Unstable

- 10.3690 g

- 10.103690 g

A&D	U	S	,	-	0	1	8	.	3	6	9	0	␣	␣	g	C <sub>R</sub>	L <sub>F</sub>	
	U	S	,	-	1	0	1	.	8	3	6	9	0	␣	␣	g	C <sub>R</sub>	L <sub>F</sub>
DP	U	S	␣	␣	␣	-	1	8	.	3	6	9	0	␣	␣	g	C <sub>R</sub>	L <sub>F</sub>
KF	-	␣	␣	1	8	.	3	6	9	0	␣	␣	␣	␣	C <sub>R</sub>	L <sub>F</sub>		
MT	S	D	␣	␣	-	1	8	.	3	6	9	0	␣	g	C <sub>R</sub>	L <sub>F</sub>		
NU	-	0	0	1	8	.	3	6	9	0	C <sub>R</sub>	L <sub>F</sub>						

### Overload

Positive error

⌘ g

A&D	O	L	,	+	9	9	9	9	9	9	9	E	+	1	9	C <sub>R</sub>	L <sub>F</sub>	
DP	␣	␣	␣	␣	␣	␣	␣	␣	E	␣	␣	␣	␣	␣	␣	C <sub>R</sub>	L <sub>F</sub>	
KF	␣	␣	␣	␣	␣	␣	H	␣	␣	␣	␣	␣	␣	␣	C <sub>R</sub>	L <sub>F</sub>		
MT	S	I	+	C <sub>R</sub>	L <sub>F</sub>													
NU	+	9	9	9	9	9	9	9	9	9	C <sub>R</sub>	L <sub>F</sub>						

### Overload

Negative error

-⌘ g

A&D	O	L	,	-	9	9	9	9	9	9	9	E	+	1	9	C <sub>R</sub>	L <sub>F</sub>	
DP	␣	␣	␣	␣	␣	␣	-	E	␣	␣	␣	␣	␣	␣	␣	C <sub>R</sub>	L <sub>F</sub>	
KF	␣	␣	␣	␣	␣	␣	L	␣	␣	␣	␣	␣	␣	␣	C <sub>R</sub>	L <sub>F</sub>		
MT	S	I	-	C <sub>R</sub>	L <sub>F</sub>													
NU	-	9	9	9	9	9	9	9	9	9	C <sub>R</sub>	L <sub>F</sub>						

␣ Space, ASCII 20h  
 C<sub>R</sub> Carriage Return, ASCII 0Dh  
 L<sub>F</sub> Line Feed, ASCII 0Ah

# 8. STANDARD INPUT AND OUTPUT INTERFACE

## 8.1. RS-232C Interface

The balance is a DCE device. Connect the balance to a personal computer (DTE) using a straight through cable.

- Transmission system : EIA RS-232C
- Transmission form : Asynchronous, bi-directional, half duplex
- Transmission rate : 10 times/second or 5 times/second (same as data refresh rate)
- Data format : Baud rate : 600, 1200, 2400, 4800, 9600, 19200bps
  - Data bits : 7 or 8 bits
  - Parity : Even, Odd (Data bits 7 bits)
  - None (Data bits 8 bits)
  - Stop bit : 1 bit
  - Code : ASCII

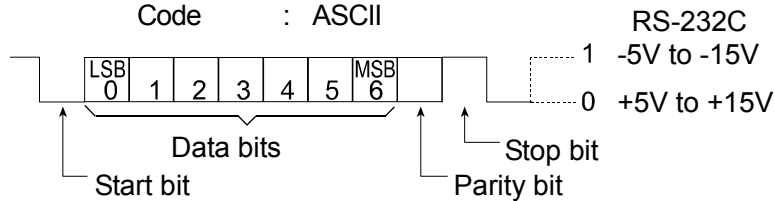

### Pin assignments

Pin assignments of the RS-232C communication cable for PC or PLC (D-Sub 9 pin side)

Pin No.	Signal name	Direction	Description
1	-	-	No connection
2	RXD (TXD)	Output	Transmit data
3	TXD (RXD)	Input	Receive data
4	-	-	No connection
5	SG	-	Signal ground
6	DSR	Output	Data set ready
7	RTS	Input	Request to send
8	CTS	Output	Clear to send
9	-	-	No connection

D-Sub 9 pin plug of RS-232C cable for the PC or PLC

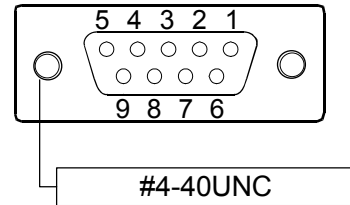

Pin names mean one for the DTE side.

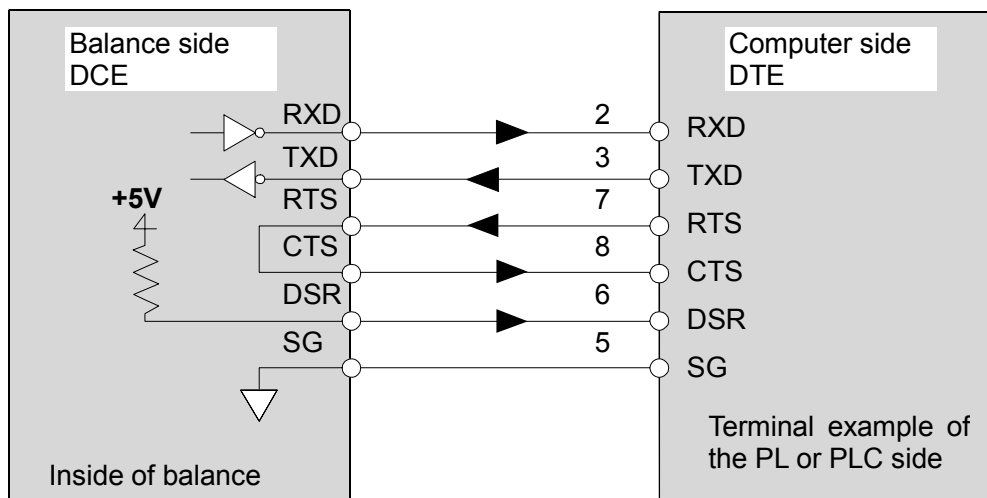



## Connection to a computer using the RS-232C Interface

### Features

The balance is of the DCE type (Data Communication Equipment), which can be connected to a personal computer using the RS-232C interface. Before connection, read the personal computer manual thoroughly.

### Using Windows Communication Tools Software (WinCT)

When Windows is used as an operating system in a personal computer, the WinCT software can be used to transmit the weighing data to the personal computer.

The WinCT software has three communication methods: "RsCom", "RsKey" and "Rsweight". Refer to the WinCT instruction manual.

The current version of the WinCT can be downloaded from the A&D website.

### RsCom

- RsCom can transmit commands to control the balance.
- RsCom can make bi-directional communication between the balance and a personal computer using the RS-232C interface.
- RsCom can display or store the data using a text file format. RsCom can also print the data using a printer connected to the personal computer.
- When several ports of a personal computer have balances connected, the personal computer can communicate with each balance simultaneously.
- RsCom can share a personal computer with other application software.

### RsKey

- RsKey can transmit the weighing data output from the balance directly to other application software such as Microsoft Excel.
- RsKey can be used with most application software.

### RsWeight

- Can retrieve the weight data from the balance and display the data as a graph in real time.  
Can calculate and display the maximum, minimum, average, standard deviation and coefficient of variation.

### Using the WinCT software, the balance can do the following:

- **Analyzing the weighing data and the statistics input by "RsKey"**  
The weighing data can be input directly into an Excel worksheet. Then, Excel can analyze the data to obtain total, average, standard deviation, maximum and minimum value, and display them in a graph.
- **Controlling the balance using commands from a personal computer**  
By using "RsCom", the personal computer sends commands such as "re-zero" or "send weighing data" to the balance and controls the balance.
- **Receiving weighing data at a certain interval**  
The weighing data can be received at a certain interval and data characteristic with elapsed time can be obtained.
- **Using a personal computer as an external indicator**  
With the "RsKey" test mode function, a personal computer can be used as an external display for the balance. (To do this, set the balance data output mode to stream mode.)

## 8.2. Commands

### Command List

**Note** A command has a terminator added, that is specified using "*S iF, [rLF*" of the function table, and is sent to the balance.

Commands to query weighing data	
C	Cancels the S or SIR command.
Q	Requests the weighing data immediately.
S	Requests the weighing data when stabilized.
SI	Requests the weighing data immediately.
SIR	Requests the weighing data continuously.

Commands to control the balance	
CAL	Performs calibration using the internal weight.
EXC	Performs calibration using the external weight.
OFF	Goes into standby mode. (Weighing value output is not performed)
ON	Goes into weighing mode from standby mode.
P	Switches between weighing mode and standby mode.
PRT	Confirms operations at the calibration etc.
R	Performs re-zero. #1
RNG	Switches the minimum display.
TR	Tares the balance. #1
U	Changes the weighing speed.(Response speed)

Commands to request data	
?ID	Outputs the identification number.
?PT	Outputs the tare value. #1
?SN	Outputs the serial number of the balance.
?TN	Outputs the model name of the balance.
?TM	Outputs time.
?DT	Outputs date.

Command to set data	
PT:***.*** g	Sets the tare value. #1
TM:**:**:**	Sets time. Example) 12:34:56 TM: 12/34/56
DT:**/**/**	Sets date. Example) October 1, 2015 DT: 15/10/01
ID:**/**/**	Sets the ID number.

- #1  Command R assumes the point as zero and sets the display to zero.  
 Command TR cancels the tare weight when the displayed value is greater than zero.  
 The canceled tare value can be read using the command ?PT.

- Command `PT:***.*** g` sets the tare value digitally.  
An example of this command sets a negative target value and fills with the sample until the display becomes zero. For details, refer to page 37.
  - Step 1 Place a container.
  - Step 2 Set the display to zero using the R command.
  - Step 3 Set a target value using the PT: command.

## Acknowledge Code And Error Codes

When the "Serial interface function (*S iF*)" parameter is set to "Error Code on", the balance outputs <AK> code or error code to each command as follows:

<AK> (06h)                      Acknowledge in ASCII code.

- When the balance receives a command to request data and can not process it, the balance transmits an error code (EC, E<sub>xx</sub>).

When the balance receives a command to request data and can process it, the balance outputs the data.

- When the balance receives a command to control the balance and can not process it, the balance transmits an error code (EC, E<sub>xx</sub>).

When the balance receives a command to control the balance and can process it, the balance transmits the acknowledge code.

<AK> (06h)                      Acknowledge in ASCII code.

Among commands to control the balance, the following transmit the acknowledge code both when the balance receives the command and when the balance has accomplished the command. If the command can not be processed properly, the balance transmits an error code (EC, E<sub>xx</sub>). This error can be released using the CAL command. xx is error code number.

CAL command	(Calibration command using internal weight)
EXC command	
ON command	(Display ON command)
P command	(Display ON/OFF command)
R command	(RE-ZERO command)
TR command	(Tare command)

- When a communication error has occurred due to external noise, or a parity error has occurred due to transmission error, the balance transmits an error code (EC, E<sub>xx</sub>). In this case, send the command again. xx is error code number.

## Settings Related To RS-232C

Concerning the RS-232C, the balance has two functions: "Data output (*dout*)" and "Serial interface (*S iF*)". Set each function as necessary.

## Command Examples

This example uses the "Error on" of "5 if" so that the <AK> (06h) code is output.

### ON command (turning on the balance)

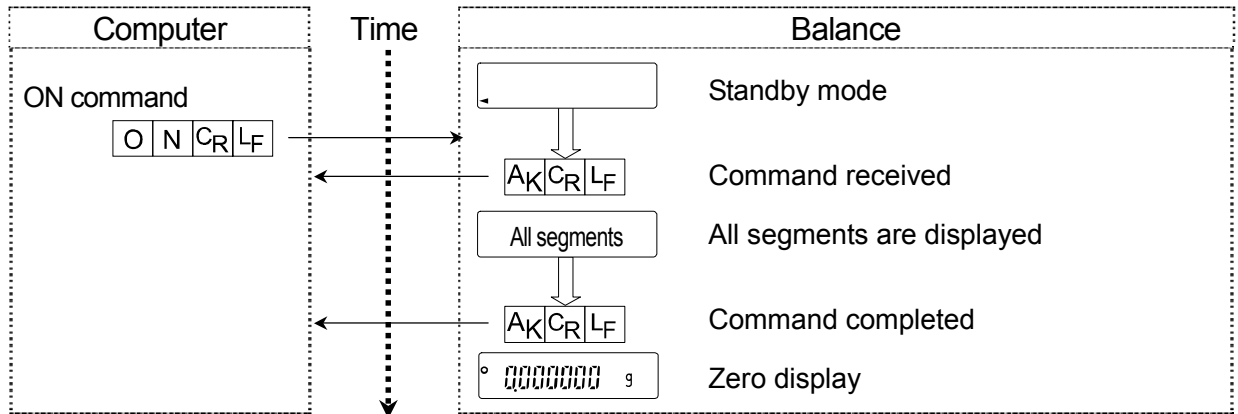

### R command (Re-zeroing the display)

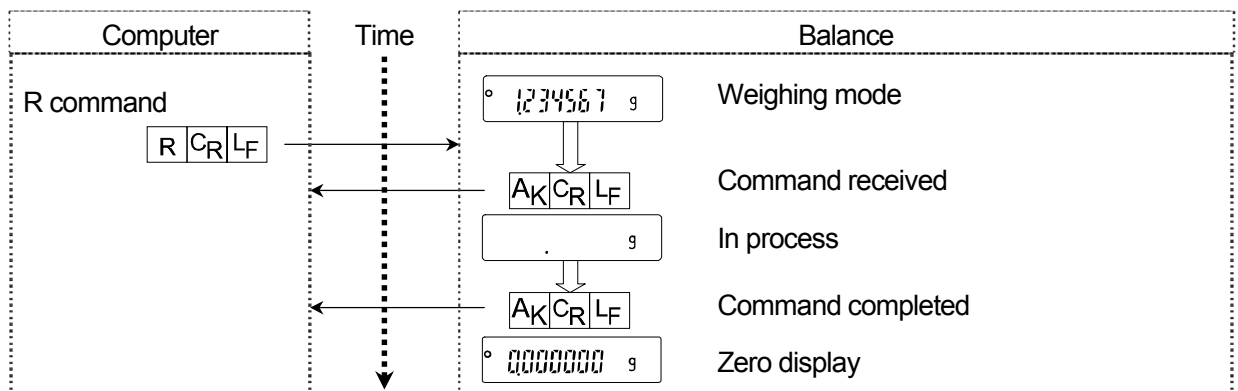

### CAL command (Calibration with internal weight)

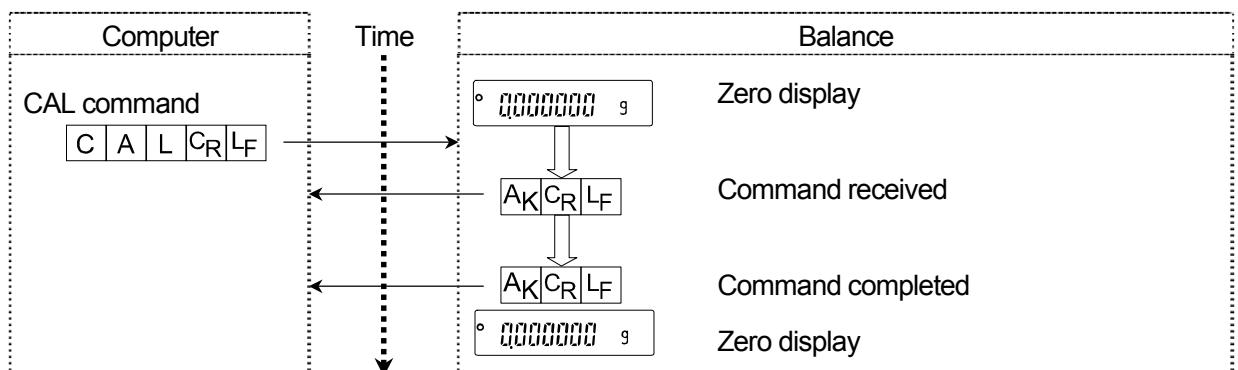

### Error code

This example is of an error using the R command. "Error 1" is used. The balance transmits an error code when the received command can not be achieved.

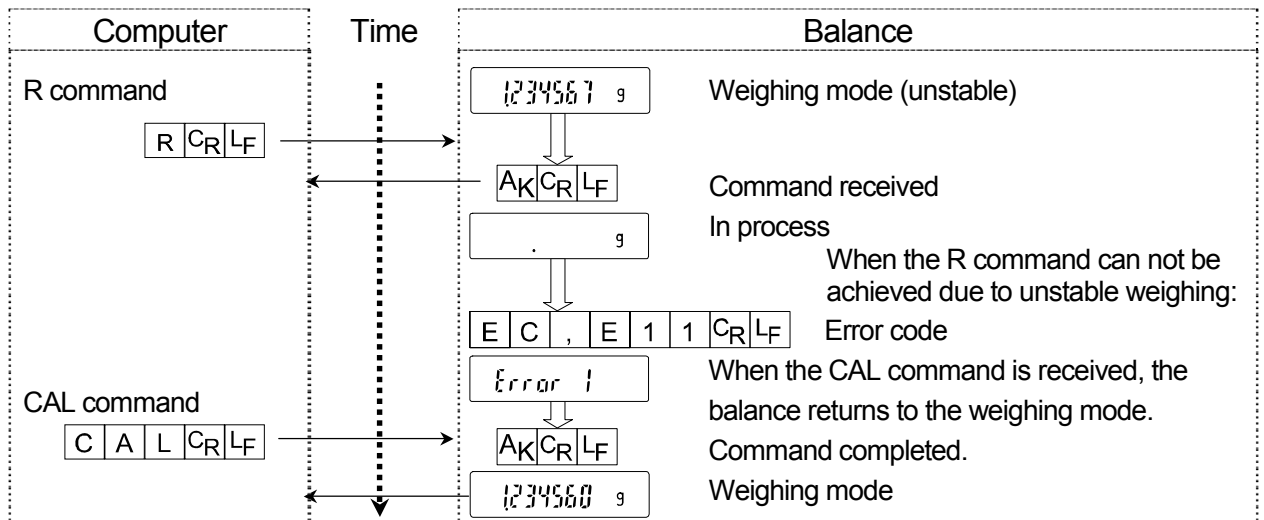

### Weighing with a tare

This example uses "Error 1" of "SIF" so that the <AK> (06h) code is output.

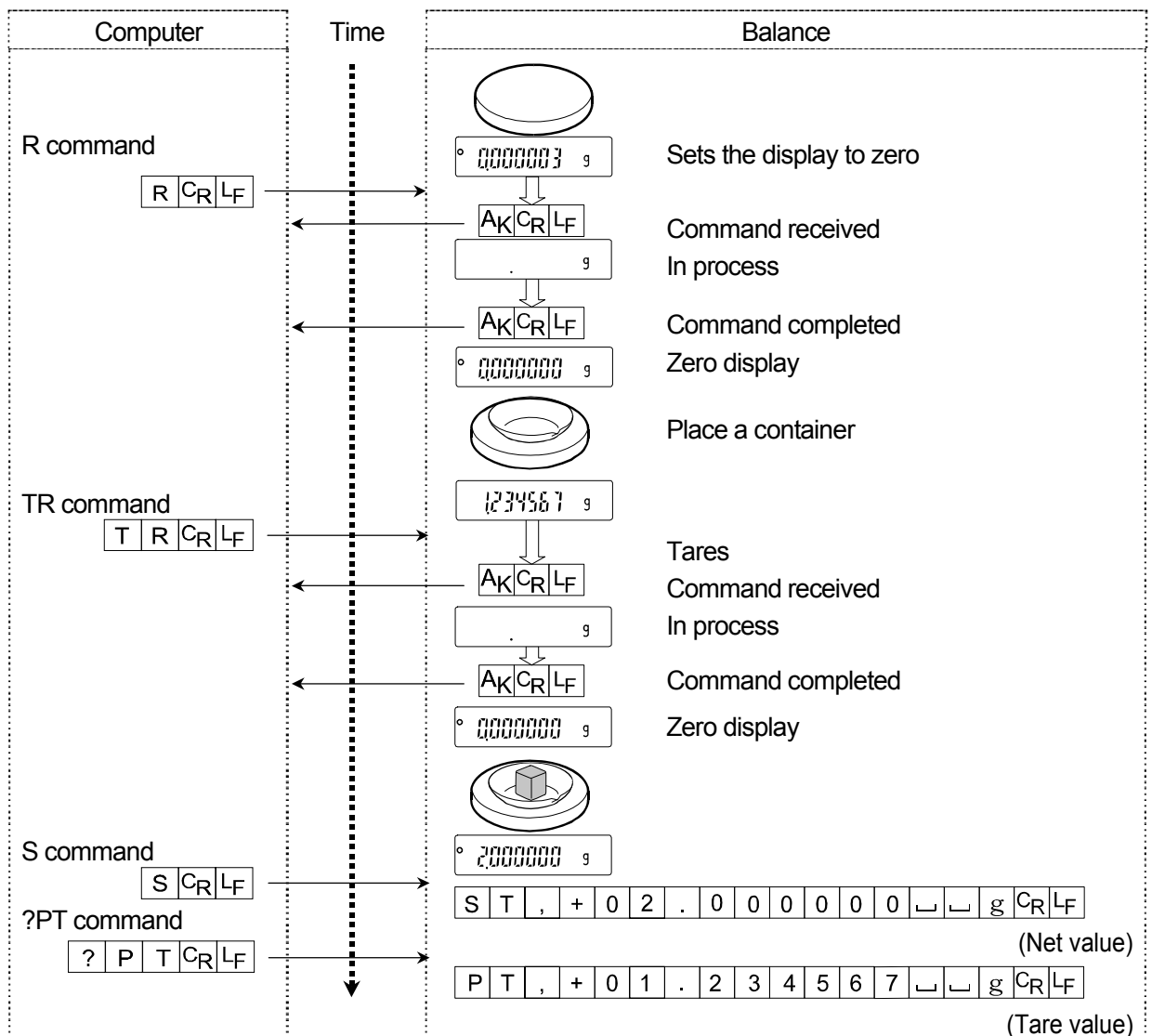

### Setting a negative target value and filling with a sample until the display becomes zero

This example uses "ErLn" of "SIF" so that the <AK> (06h) code is output.

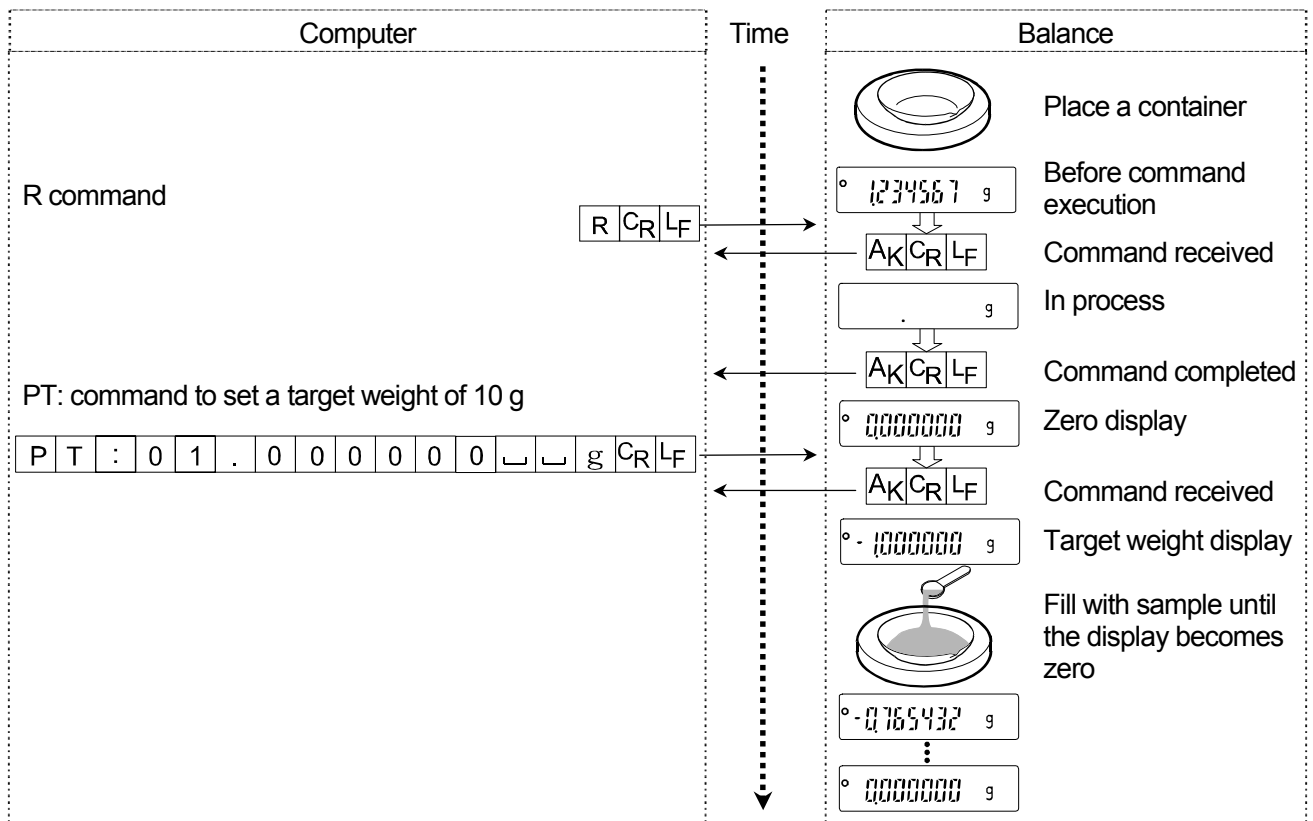

# 9. MAINTENANCE

## 9.1. Treatment Of The Balance

- When cleaning, remove the weighing pan and pan support from the balance and attach the waterproof cover for cleaning the balance.
- Do not use organic solvents to clean the balance.
- Do not disassemble the balance. Contact the local A&D dealer if the balance needs service or repair.
- Use the original packing material for transportation. When packing, fasten the waterproof cover to the balance using the tape by following the instructions at the figure below.
- Consider "2. UNPACKING THE BALANCE" and "3.PRECAUTIONS" when operation the balance.

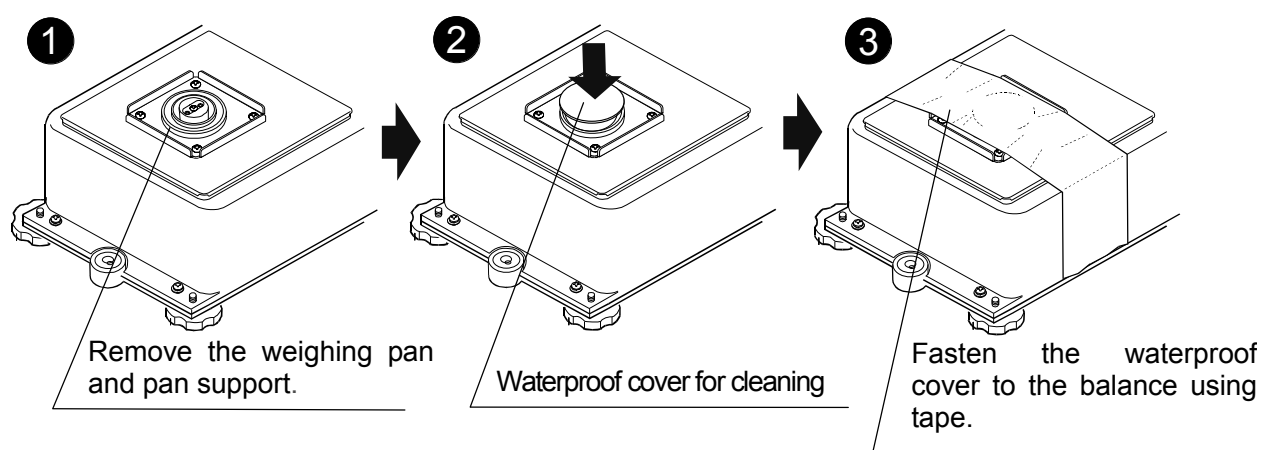

## 9.2. Error Codes

Error code	Description
EC,E00	<b>Internal error</b> If displaying this error continuously, contact your local A&D dealer to repair the balance.
EC,E11	<b>Stability error</b> The balance can not stabilize due to an environmental problem. Check around the pan. Prevent vibration, drafts, temperature changes, static electricity and magnetic fields, from influencing the balance.
EC,E16	<b>Internal weight error</b> Applying the internal weight does not yield a change in the weight value as specified. Confirm that there is nothing on the pan and perform the weighing operation from the beginning again.
EC,E17	<b>Internal weight error</b> The internal weight application mechanism does not function properly. Perform the weighing operation from the beginning again.
EC,E20	<b>Calibration weight error</b> The calibration weight is too heavy. Confirm the calibration weight value. Press the <input type="button" value="CAL"/> key to return to the weighing mode.



Error code	Description
EC,E21	<b>Calibration weight error</b> The calibration weight is too light. Check around the pan. Confirm the calibration weight value. Press the <b>CAL</b> key to return to the weighing mode.
E	<b>Overload error</b> A sample beyond the balance weighing capacity has been placed on the pan. Remove the sample from the pan.
-E	<b>Underload error</b> The weight value is too light. Confirm that the weighing pan and pan support are properly installed. Press the <b>ON:OFF</b> key two times to return to the weighing mode. If the error still persists, calibrate the balance.
EC,E00	<b>Communications error</b> A protocol error occurred in communications. Confirm the format, baud rate and parity.
EC,E01	<b>Undefined command error</b> An undefined command was received. Confirm the command.
EC,E02	<b>Not ready</b> A received command can not be processed. Example: <ul style="list-style-type: none"> <li><input type="checkbox"/> The balance received a "Q" command, but not in the weighing mode.</li> <li><input type="checkbox"/> The balance received a "Q" command while processing a RE-ZERO command.</li> </ul> Adjust the delay time to transmit a command.
EC,E03	<b>Timeout error</b> If the timeout parameter is set to "t-UP on", the balance did not receive the next character of a command within the time limit of one second. Confirm the communication.
EC,E04	<b>Excess characters error</b> The balance received excessive characters in a command. Confirm the command.
EC,E06	<b>Format error</b> A command includes incorrect data. Example: <ul style="list-style-type: none"> <li><input type="checkbox"/> The data is numerically incorrect. Confirm the command.</li> </ul>
EC,E07	<b>Parameter setting error</b> The received data exceeds the range that the balance can accept. Confirm the parameter range of the command.
Other error code	If an error described above can not be released or other errors are displayed, contact the local A&D dealer.

## **9.3. Checking The Balance Performance And Environment**

---

The balance is a precision instrument. When the operating environment or the operating method is inadequate, correct weighing can not be performed. Place a sample on the pan and remove it, and repeat this several times. If the balance seems to have a problem with repeatability or to perform improperly, check as described below. If improper performance persists after checking, contact the local A&D dealer for repair.

### **Checking that the operating environment or weighing method is proper**

#### **Operating environment**

- Is the weighing table solid enough?
- Is the balance level?
- Is the operating environment free from vibration and drafts?
- Is there a strong electrical or magnetic noise source such as a motor near the balance?

#### **Weighing method**

- Does the weighing pan rim touch anything? Is the weighing pan installed correctly?
- Is the RE-ZERO button touched before placing a sample on the weighing pan?
- Is the sample placed in the center of the weighing pan?
- Has the balance been calibrated using the internal weight (one-touch calibration)?
- Has the balance been warmed up for one hour before weighing? (At the AD-4212D-33/32, duration of four hours or more are required.)

#### **Sample and container**

- Has the sample absorbed or lost moisture due to the ambient conditions such as temperature and humidity?
- Has the temperature of the container been allowed to equalize to the ambient temperature?
- Is the sample charged with static electricity?
- Is the sample of magnetic material such as iron? There are cautions about weighing magnetic materials.

### **Checking that the balance performs properly**

- Check the balance performance using an external weight. Be sure to place the weight in the center of the weighing pan.
- Check the balance repeatability, linearity and calibrated value using external weights with a known value.
- Check whether the calibration is performed correctly. If an error occurs and the calibration can not be performed quickly, the balance may not measure correctly.

## **9.4. Asking For Repair**

---

If the balance needs service or repair, contact your local A&D dealer.

The balance is a precision instrument. Use much care when handling the balance and observe the following when transporting the balance.

- Use the original packing material for transportation.
- Remove the weighing pan, pan support, rings and dust plate from the main unit.

## 10. SPECIFICATIONS

	AD-4212D-33	AD-4212D-32	AD-4212D-302	AD-4212D-301
Weighing capacity	32 g	32 g 5.1 g	320 g	320 g
Maximum display	32.000084 g	32.00008 g 5.100009 g *1	320.00084 g	320.0084 g
Minimum display	0.001 mg	0.01 mg 0.001 mg	0.01 mg	0.1 mg
Repeatability (Standard deviation)	0.002 mg *2	0.02 mg 0.004 mg *2	0.02 mg *3	0.07 mg *3
Linearity	±0.02 mg	±0.03 mg	±0.15 mg	±0.25 mg
Stabilization time (Typical at <b>FAST</b> )	Approx. 7 seconds	Approx. 7 seconds	Approx. 7 seconds	Approx. 3 seconds
Sensitivity drift	±2 ppm/°C (10 °C to 30 °C)			
Operating environment	5 °C to 40 °C, 85 %RH or less (No condensation)			
Display refresh rate	5 times/second or 10 times/second			
Environmental sensors	Resolution: Temperature ±1.5 °C, Humidity ±10 %, Air pressure ±10 hPa Applicable range: 5 °C to 40 °C			
Display mode	gram			
Communication function	RS-232C			
External calibration weight	30 g 20 g 10 g 5 g 2 g 1 g	30 g 20 g 10 g 5 g 2 g 1 g	300 g 200 g 100 g 50 g 20 g 10 g	300 g 200 g 100 g 50 g
Size of loading area for weighing mm	Weighing pan: φ 34 mm		Weighing pan: φ 50 mm	
External dimensions	259(W) x 466(D) x 326(H) mm			
Power supply & AC adapter type	Power consumption: Approx. 30VA (supplied to the AC adapter ) Confirm that the adapter type is correct for the local voltage and power receptacle type.			
Mass	Approx. 3.6 kg			

- The operating environment does not include excessive change of ambient temperature, humidity, vibration, drafts, magnetic fields and static electricity.
  - The internal weight may change due to corrosion or other damage caused by the operating environment, or due to aging. Check the internal weight periodically and correct the internal weight value if necessary.
- \*1 When placing the tare weight within the standard range, if using the smart range, the weighing sample can be weighed within the precision range.
- \*2 This is a figure measured by loading and unloading a 1g weight on the device using the automatic machine.
- \*3 The repeatability for 10 gram within the weighing capacity.

# 11. EXTERNAL DIMENSIONS

- AD-4212D-33/32

**Pan support dimensions**

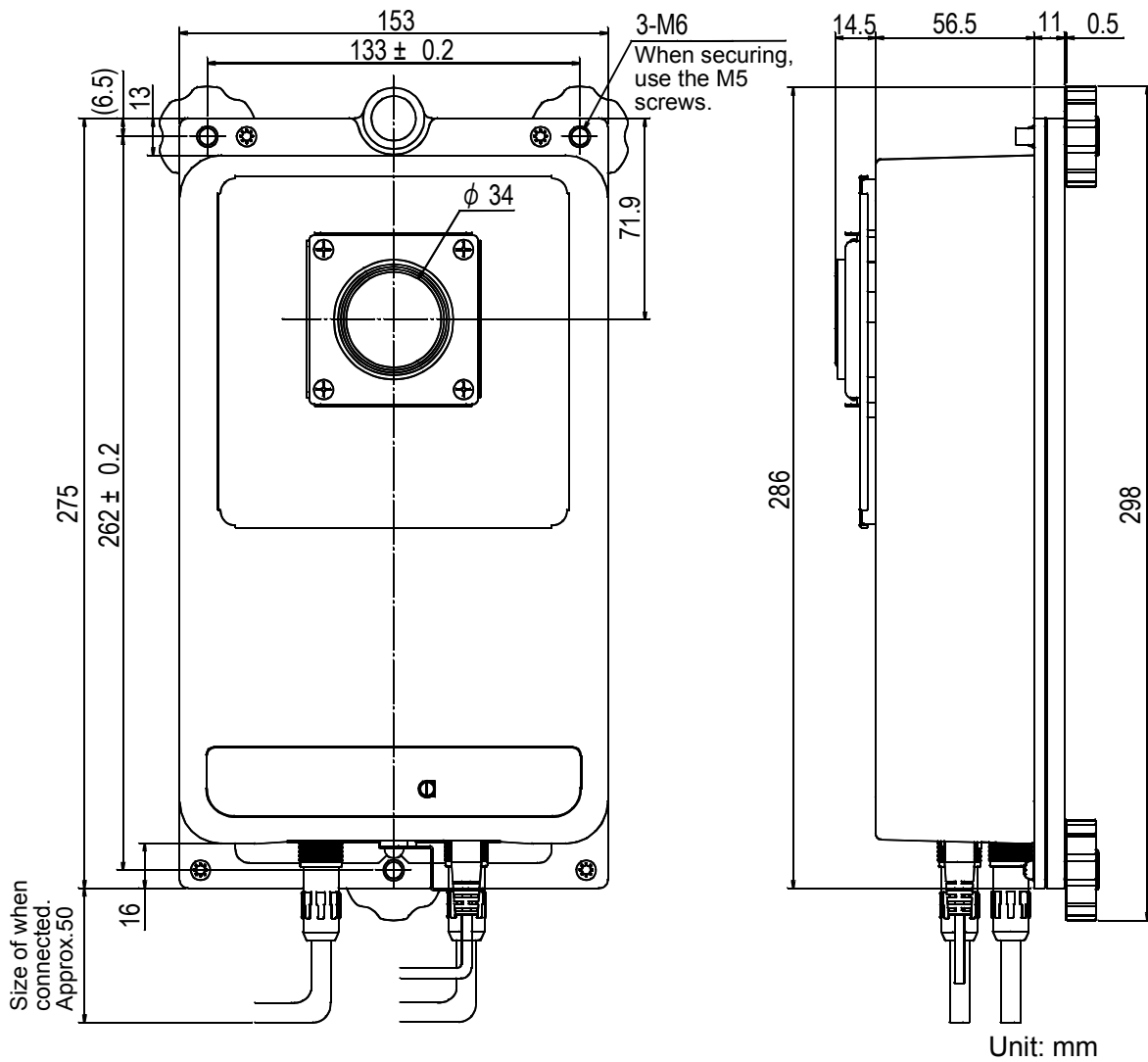
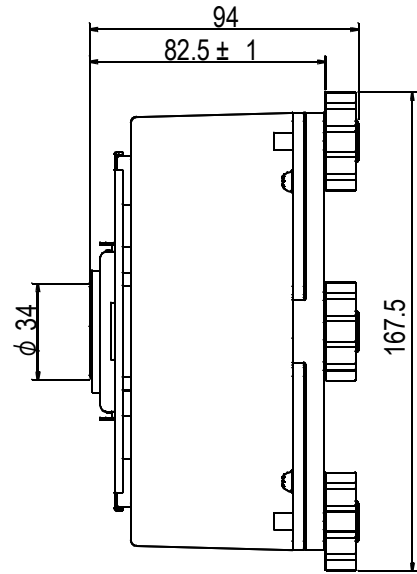
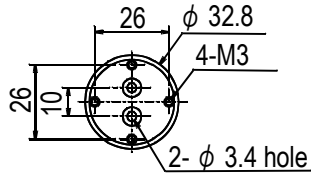

- AD-4212D-302/301

**Pan support dimensions**

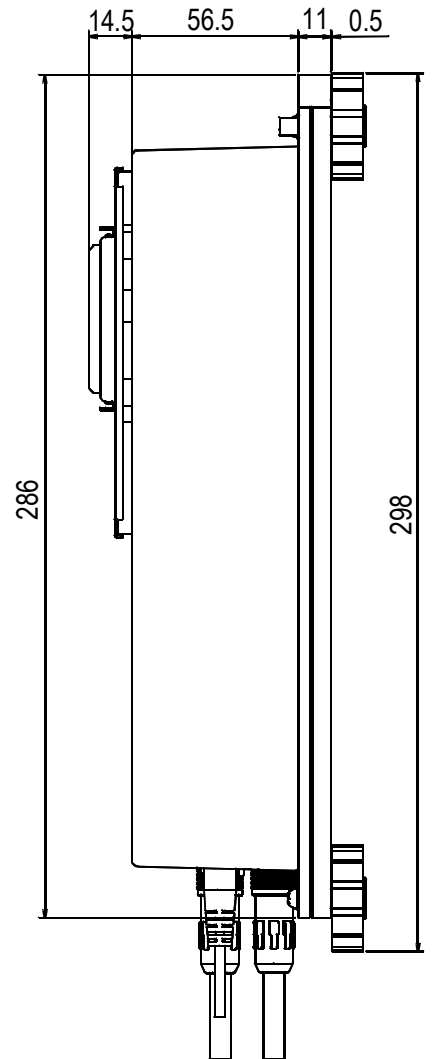
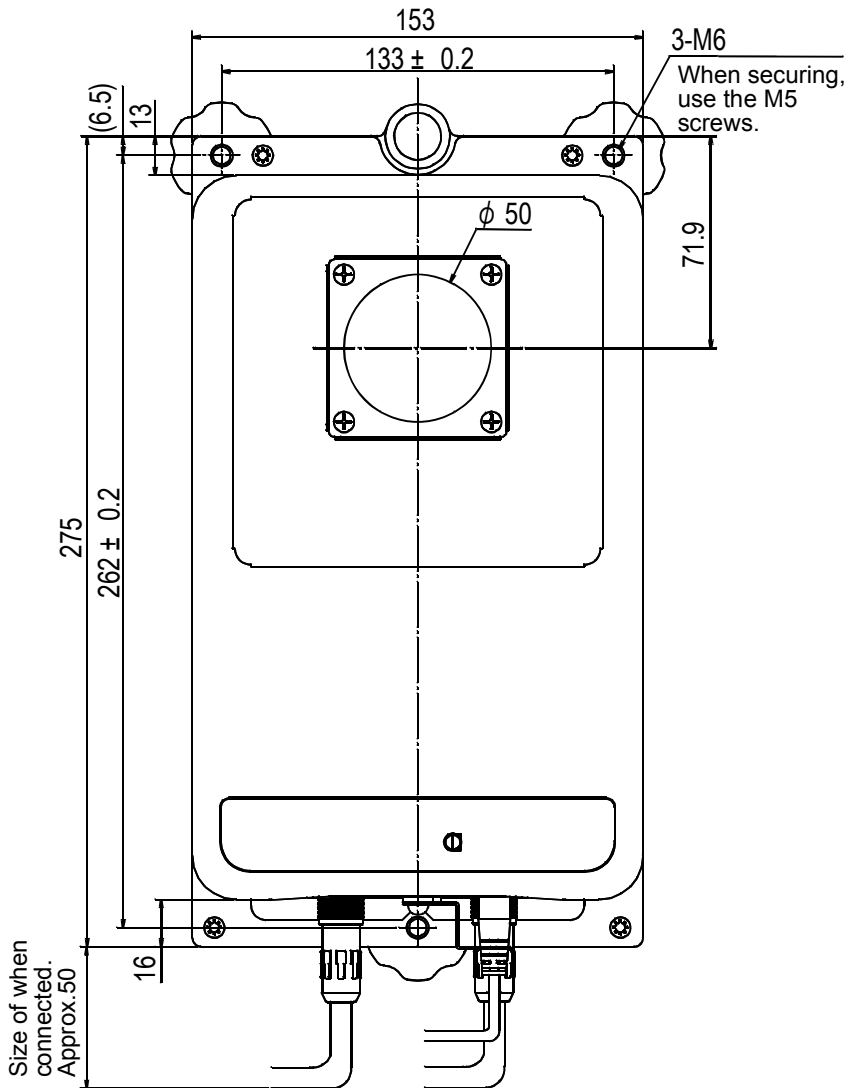
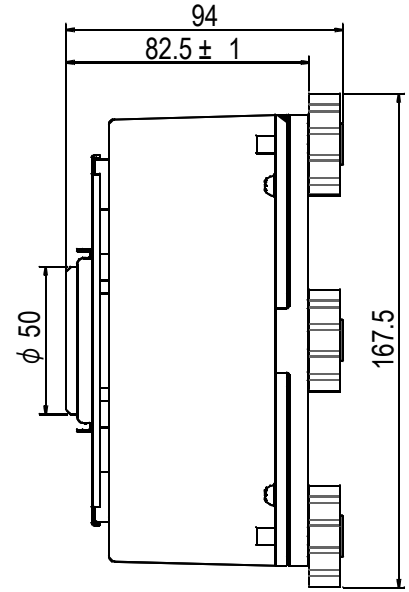
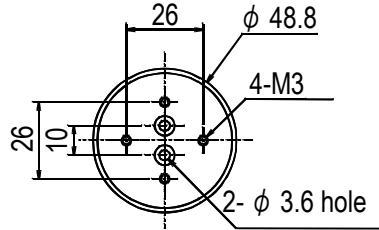

Unit: mm

## 12. OPTIONS

**AX-KO3590-1000 (For external display) RS-232C cable 10m**

**AX-KO4472-1000 (For PC, PLC) RS-232C cable 10m**

### **AX-USB-9P: USB converter/Cable set**

- USB converter (D-Sub 9 pin - USB)
  - RS-232C cable (D-Sub 9 pin - D-Sub 9-pin)
- \* This RS-232C cable is not used with the AD-4212D series.

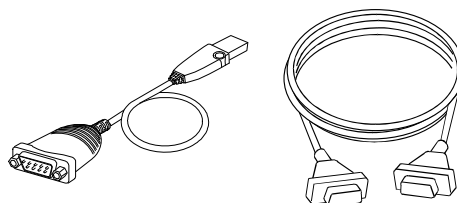

### **AD-8922A: Remote controller**

- The AD-8922A can receive the weighing data, and performs re-zero and calibration manually.
- The AD-8922A can output the data using BCD (AD-8922A-01), comparator (AD-8922A-04), or analog out (AD-8922A-06), by selection of the option installed in the AD-8922A.

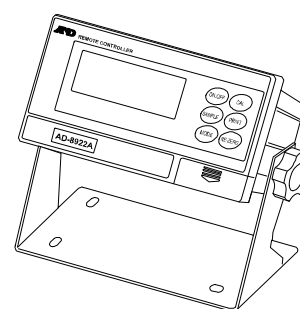

### **AD-8923-BCD/CC: Remote controller**

- The AD-8923-BCD or AD-8923-CC can receive the weighing data, and performs re-zero and calibration manually.
- The AD-8923-BCD can output the data using BCD. The AD-8923-CC can output the data using CC-Link.

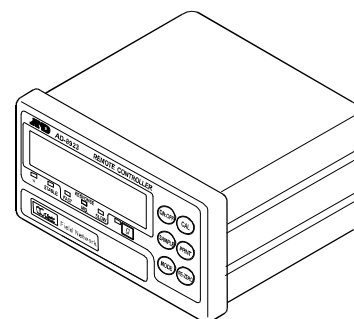

### **AD-8526: Ethernet converter**

- The AD-8526 can convert the AD-4212D RS-232C data, for output to a local area network (LAN).

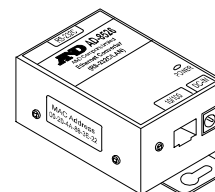

### **AD-1683: DC static eliminator**

- A compact design with efficient static elimination
- No air blowing from a fan allows precision weighing

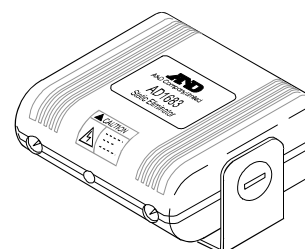

### **AD-1684A: Electrostatic field meter**

- This option measures the amount of the static charge on the sample, tare or peripheral equipment and displays the result.  
If those are found to be charged, discharge them using the AD-1683 DC static eliminator.

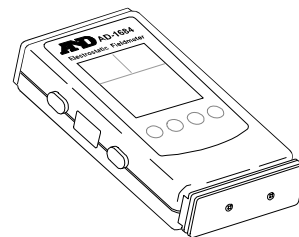

### **AD-8121B Printer**

- Compact thermal dot-matrix printer
- Statistical function, clock and calendar function, interval print function, graphic print function, dump print mode
- 5 x 7 dots, 16 characters per line
- Print paper (AX-PP143, 45 (W) x 50 (L) mm , ø65 mm)
- AC adapter or alkaline battery

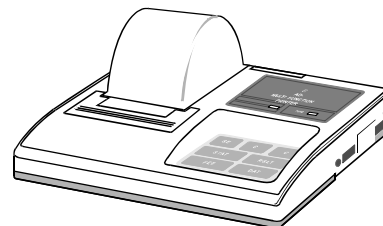

## 13. TERMS/INDEX

### Terms

<b>Stable value</b>	The weight value when the stabilization indicator appears.
<b>Environment</b>	Ambient conditions such as vibration, drafts, temperature, static electricity or magnetic fields which affect the weighing operation.
<b>Calibration</b>	Adjustment of the balance using the calibration weight so that it can weigh accurately.
<b>Output</b>	To output the weighing data using the RS-232C interface.
<b>Zero point</b>	A weighing reference point or the zero display. Usually refers to the value displayed when nothing is on the weighing pan.
<b>Digit</b>	Unit of minimum display. Used for the balance, the minimum displayable weighing value.
<b>Tare</b>	To cancel the weight of a container which is not included in the weighing data.
<b>Re-zero</b>	To set the display to zero.
<b>GLP</b>	Good Laboratory Practice.
<b>Repeatability</b>	Variation in measured values obtained when the same weight is placed and removed repetitively. Usually expressed as a standard deviation. e.g. Standard deviation=1 digit: This means that the measured values fall within $\pm 1$ digit at a probability of about 68%.
<b>Stabilization time</b>	Time required after a sample being placed, until the stabilization indicator illuminates and the weighing data is displayed.
<b>Sensitivity drift</b>	An affect that a change in temperature causes to the weighing data. Expressed as temperature coefficient. e.g. Temperature coefficient = 2 ppm/ $^{\circ}$ C : If a load is 100 g and the temperature changes by 10 $^{\circ}$ C, the value displayed changes by the following value. $0.0002\%/^{\circ}$ C x 10 $^{\circ}$ C x 100 g = 2 mg



# Index

Symbols	
└	Space mark ..... 29

## A

AC adapter	6, 9, 11, 14
AC adapter type	41
AD-1683	12, 44
AD-1684A	45
AD-1691	3, 21
AD-8121B	45
AD-8526	4, 44
AD-8922A	3, 4, 44
AD-8923-BCD	2, 44
AD-8923-CC	4, 44
AK code	34, 35, 36, 37
<i>ErCd</i> AK, Error code	23
AK, Error code	23
Ambient humidity	12
AND-MEET	2
Anti-static agent	12
<i>AP-b</i> Auto print difference	22, 25
<i>AP-P</i> Auto print polarity	22, 25
<i>Ar-d</i> Zero after output	23, 25
<i>Rt-F</i> Auto feed	23
Auto feed	23
Auto print	22, 25
Auto print difference	22
Auto print polarity	22
AX-KO3705-1000	4
AX-KO3705-200	4
AX-KO3705-500	4
AX-KO4472-1000	3, 4, 8
AX-USB-9P	3, 44

## B

<i>bRSFnc</i> Environment & Display	22
Baud rate	23, 30

BCD	2, 4, 44
<i>bPS</i> Baud rate	23
Breeze break	6, 12
<i>btPr</i> Data bit, parity bit	23
Bubble spirit level	6

## C

Cable set	44
<i>CR in</i> One-touch calibration	17
Calibration	16, 18, 46
One-touch calibration	17
Calibration weight	6, 16, 18
CC-Link	2, 4, 44
Charged material	12
Command	32, 35, 36, 37
Communication function	41
<i>Cond</i> Condition	22, 24
Conductive acrylic fiber	12
Connect	3, 4
<i>CR</i> Carriage return	29
<i>CrLF</i> Terminator	23, 32

## D

Data bits	23
Data bits & parity bits	30
Data format	23, 26, 29
Data output	23
Data output mode	22, 25
Data output pause	23
Date	23, 27
DC static eliminator	12, 44
Decimal point	22, 24, 27
Digit	46
Discharge	12
Display lock function	22
Display mode	41
Display refresh rate	22, 24, 41
<i>dout</i> Data output	22, 23, 25

Dust plate .....	6	Interval time .....	23
<b>E</b>		<b>L</b>	
E .....	39	LAN .....	4
-E .....	39	Leveling foot .....	6, 7
Earth ground .....	12	LF Line feed .....	29
EC,E00 .....	38, 39	Linearity .....	41
EC,E01 .....	39	<b>M</b>	
EC,E02 .....	39	Magnetic substance .....	20
EC,E03 .....	39	Mass .....	41
EC,E04 .....	39	Maximum display .....	41
EC,E06 .....	39	MID .....	16
EC,E07 .....	39	Minimum display .....	41
EC,E11 .....	38	Minimum weighing value .....	2
EC,E16 .....	38	<b>O</b>	
EC,E17 .....	38	Operating environment .....	41
EC,E20 .....	38	<b>P</b>	
EC,E21 .....	39	Pan support .....	6
Electrostatic field meter .....	45	Pan support boss .....	6
Environment .....	40	Parity .....	23, 30
Environmental sensors .....	41	Personal computer .....	3
ErrCd AK, Error code .....	34, 35, 36, 37	Pilot lamp .....	6, 14
Error code .....	36, 38	Plastic .....	12
Ethernet converter .....	2, 44	PLC .....	4
EXC button .....	18	PLoc Display lock function .....	22
External calibration weight .....	41	Pnt Decimal point .....	22, 24
External dimensions .....	41	Powdery samples .....	12
<b>F</b>		Power plug stopper .....	6, 9
FAST .....	2, 16	Power supply .....	41
Fine range ring .....	6	Precision range .....	19
<b>G</b>		Printer .....	45
Grounding terminal .....	6	Prt Data output mode .....	22, 25
<b>I</b>		PUSE Data output pause .....	23
ID number .....	23, 27	<b>R</b>	
Insulators .....	12	R command .....	19
Int Interval time .....	23	Remote controller .....	44
Interval mode .....	22, 25		

Repeatability .....	41, 46
RESPONSE.....	22, 24
RS-232C .....	3, 4, 30, 31
RS-232C cable .....	6, 8
RS-232C connector .....	6
RsCom    Command mode for WinCT.....	31
RsKey     Data output mode for WinCT .....	31
RsWeight.....	31

## S

Sensitivity drift .....	41, 46
Serial interface .....	23
<i>S-ID</i> ID number output .....	23
<i>S-IF</i> Serial interface .....	23, 25, 26
<i>S-IF</i> Serial interface .....	23
<b>SLOW</b> .....	16
Smart range .....	2
Smart Range Function.....	19
<i>SPd</i> Display refresh rate .....	22, 24, 25
Stability band width.....	22, 24
Stabilization time .....	2, 41, 46
Stable value.....	16, 46
Standard range .....	19
Static charge .....	13
Static electricity.....	10, 46
<i>St-b</i> Stability band width .....	22
<i>St-b</i> Stability detection.....	24
<i>St-d</i> Time & Date output .....	23
Stop bit .....	30
<i>StP</i> Temperature output.....	23
Stream mode.....	22, 25

## T

Tare.....	36
Temperature .....	28
Temperature output.....	23
Terminator .....	23, 32
Time .....	23, 28
<i>t-UP</i> Timeout.....	23
Timeout.....	23
<i>trc</i> Zero tracking.....	22, 24
<i>tYPE</i> Data format .....	23, 26

## U

Underhook.....	20
USB .....	3
USB converter .....	3, 44

## W

Warm up.....	9, 14
Waterproof cap for cleaning.....	6
Weighing capacity .....	2, 14, 41
Weighing pan .....	6, 41
Weighing speed.....	10, 16
WinCT    Communication Tools.....	31

## Z

Zero	
Zero tracking.....	22, 24
Zero after output .....	23
Zero point .....	18, 46





